



# PARTS CATALOGUE

## MODEL YEAR 1993

### G9-EJ (JH72)

Frame Serial No	.H7.100101 and following
Engine Serial No	

PUBLICATION	PART NUMBER	REMARKS
OWNER'S MANUAL	LIT 19626 00 62	
ASSEMBLY	LIT-19616-G9-00	
SERVICE MANUAL	LIT 19666 00 13	
COUNTRY CLUB	LIT 1001J G9 93	

# REAR ARM - SUSPENSION

Ref. No.	Part Number	Description	Qty	Remarks
1	J56-F2110-W0-00	REAR ARM COMP. (J56-F2110-00-00)	1	
2	J10-22123-00-00	. BUSH 1	2	
3	90105-10359-00	BOLT, WASHER BASED	2	
4	90185-10115-00	NUT, SELF-LOCKING	2	
5	JG6-F2210-00-00	SHOCK ABSORBER ASSEMBLY, REAR	2	YPAD
6	97012-10050-00	BOLT (97002-10050-00)	4	
7	95601-10100-00	NUT, U (95602-10100-00)	4	

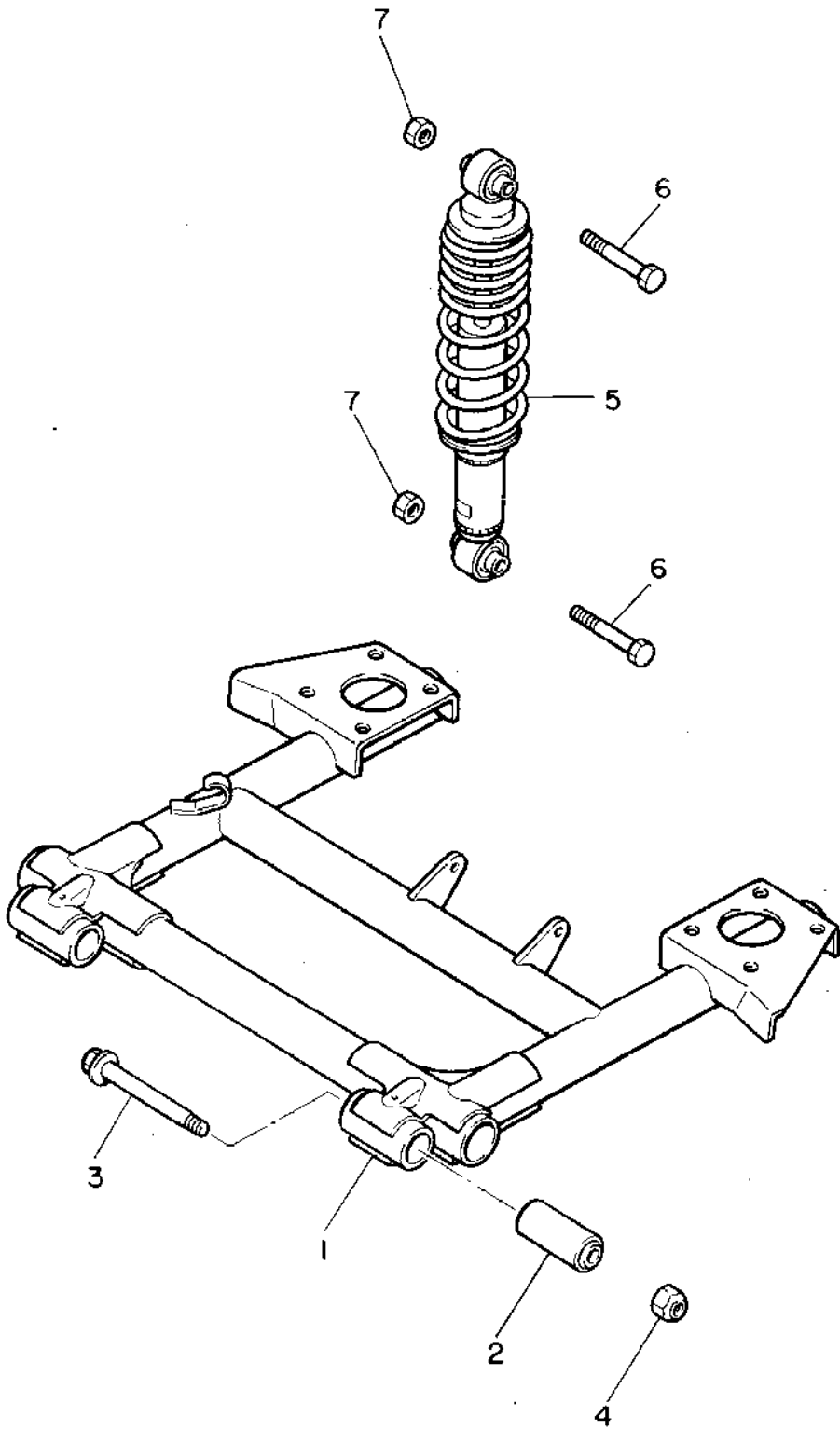

JH7100-3010

# FRAME

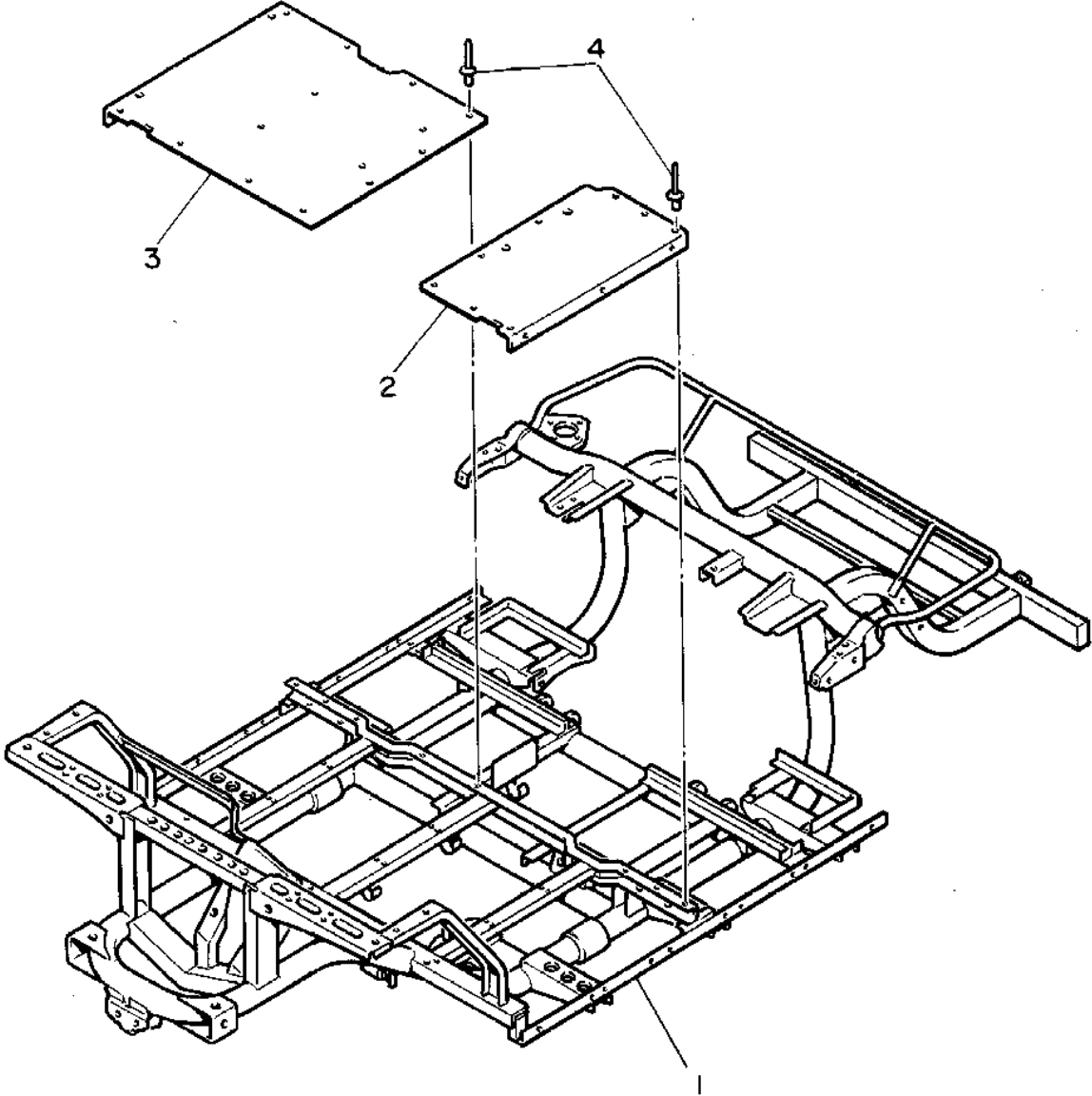

Ref. No.	Part Number	Description	Qty	Remarks
1	JG6-F2501-02-00	FRAME COMP. ....	1	YPAD
2	J55-F2571-00-00	PANEL 1 ....	1	YPAD
3	J55-F2572-00-00	PANEL 2 ....	1	YPAD
4	90267-40054-00	RIVET, BLIND ....	20	



JG6100-1020

# FRONT SUSPENSION - WHEEL

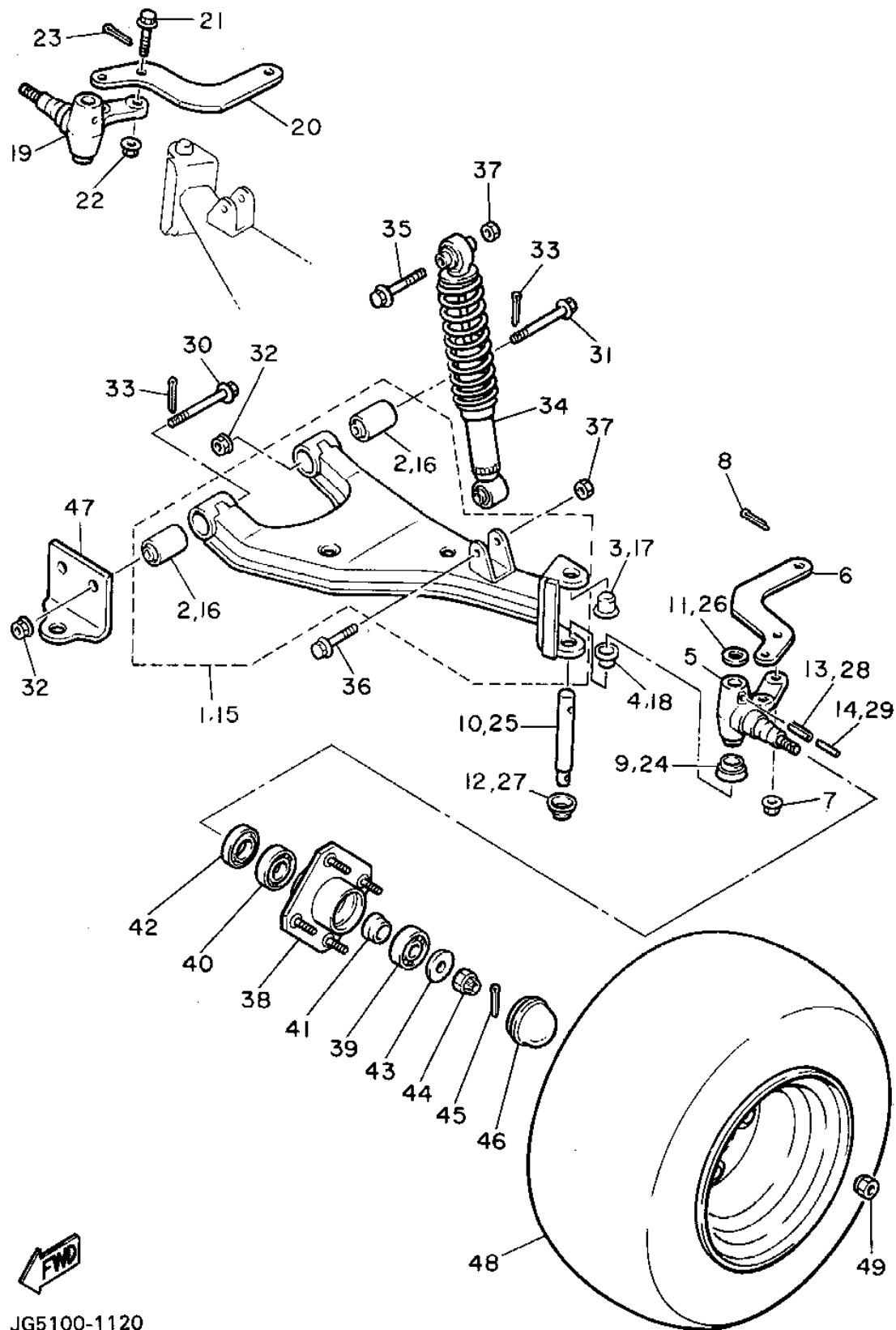

Ref. No.	Part Number	Description	Qty	Remarks
1	J55-F3570-00-00	FRONT LOWER ARM SUB-ASSEMBLY (L.H)	1	YPAD
2	J38-23526-00-00	. BUSH	2	
3	90338-17225-00	PLUG	1	
4	90386-15139-00	BUSH	1	
5	J38-23511-01-00	KNUCKLE, STEERING 1	1	
6	J38-23512-02-00	ARM, KNUCKLE 1	1	
7	90185-10115-00	NUT, SELF-LOCKING	2	
8	91401-25020-00	PIN, COTTER	2	
9	J38-23527-00-00	SEAL, DUST	1	
10	J38-23516-00-00	PIN, STEERING KNUCKLE	1	YPAD
11	90201-156J2-00	WASHER, PLAIN	1	
12	J38-23528-00-00	SEAL, DUST	1	
13	91609-60028-00	PIN, SPRING	1	
14	91609-35028-00	PIN, SPRING	1	
15	J55-F3580-00-00	FRONT LOWER ARM SUB-ASSEMBLY (R.H)	1	YPAD
16	J38-23526-00-00	. BUSH	2	
17	90338-17225-00	PLUG	1	
18	90386-15139-00	BUSH	1	
19	J38-23521-01-00	KNUCKLE, STEERING 2	1	
20	J38-23512-02-00	ARM, KNUCKLE 1	1	
21	90105-10360-00	BOLT, FLANGE	2	
22	90185-10115-00	NUT, SELF-LOCKING	2	
23	91401-25020-00	PIN, COTTER	2	
24	J38-23527-00-00	SEAL, DUST	1	
25	J38-23516-00-00	PIN, STEERING KNUCKLE	1	YPAD
26	90201-156J2-00	WASHER, PLAIN	1	
27	J38-23528-00-00	SEAL, DUST	1	

CONTINUED ON NEXT FRAME ►

JG5100-1120

# FRONT SUSPENSION - WHEEL

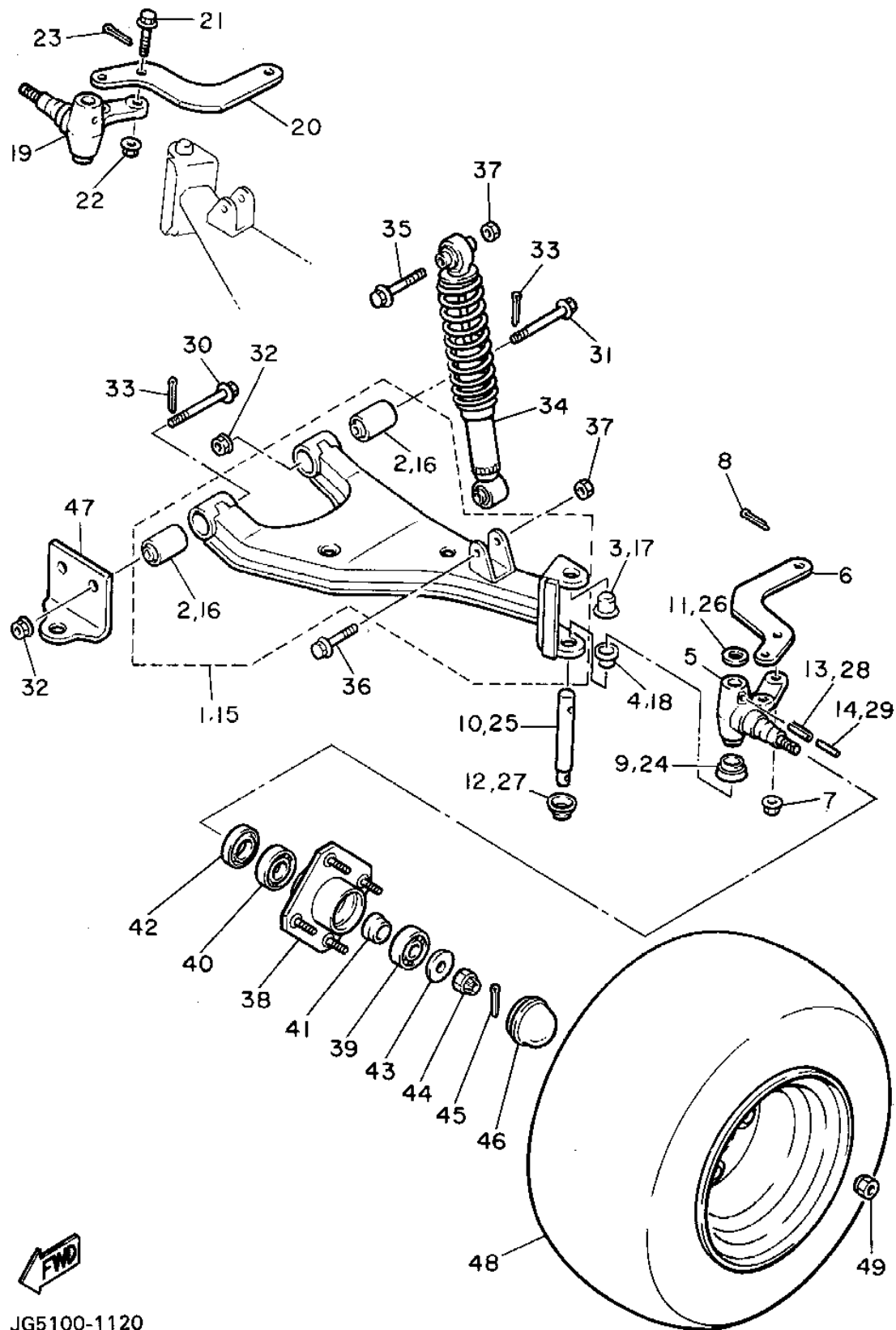

Ref. No.	Part Number	Description	Qty	Remarks
28	91609-60028-00	PIN, SPRING .....	1	
29	91609-35028-00	PIN, SPRING .....	1	
30	90105-10357-00	BOLT, FLANGE .....	2	
31	90105-10357-00	BOLT, FLANGE .....	2	
32	90185-10115-00	NUT, SELF-LOCKING .....	4	
33	91401-25020-00	PIN, COTTER .....	4	
34	JG6-F3350-00-00	SHOCK ABSORBER ASSEMBLY .....	2	
35	97002-10065-00	BOLT .....	2	
36	97012-10050-00	BOLT (97002-10050-00) .....	2	
37	95601-10100-00	NUT, U (95602-10100-00) .....	4	
38	JG5-WF511-00-00	HUB .....	2	
39	93306-20437-00	BEARING .....	2	
40	93306-00511-00	BEARING .....	2	
41	90387-241M7-00	COLLAR .....	2	
42	93102-30083-00	SEAL, OIL .....	2	
43	90209-32271-00	WASHER .....	2	
44	95601-14100-00	NUT, U (95602-14100-00) .....	2	
45	91401-25020-00	PIN, COTTER .....	2	
46	J17-25118-00-00	COVER, HUB DUST .....	2	
47	ABA-JF287-00-00	BRACKET 1 ASSEMBLY .....	1	
48	JG5-F5100-30-00	FRONT WHEEL ASSEMBLY (JG5-F5100-30-00) .....	2	
49	90179-12262-00	NUT .....	8	
38-1	90114-12800-00	. BOLT, RIBBED NECK .....	8	

JG5100-1120

# STEERING

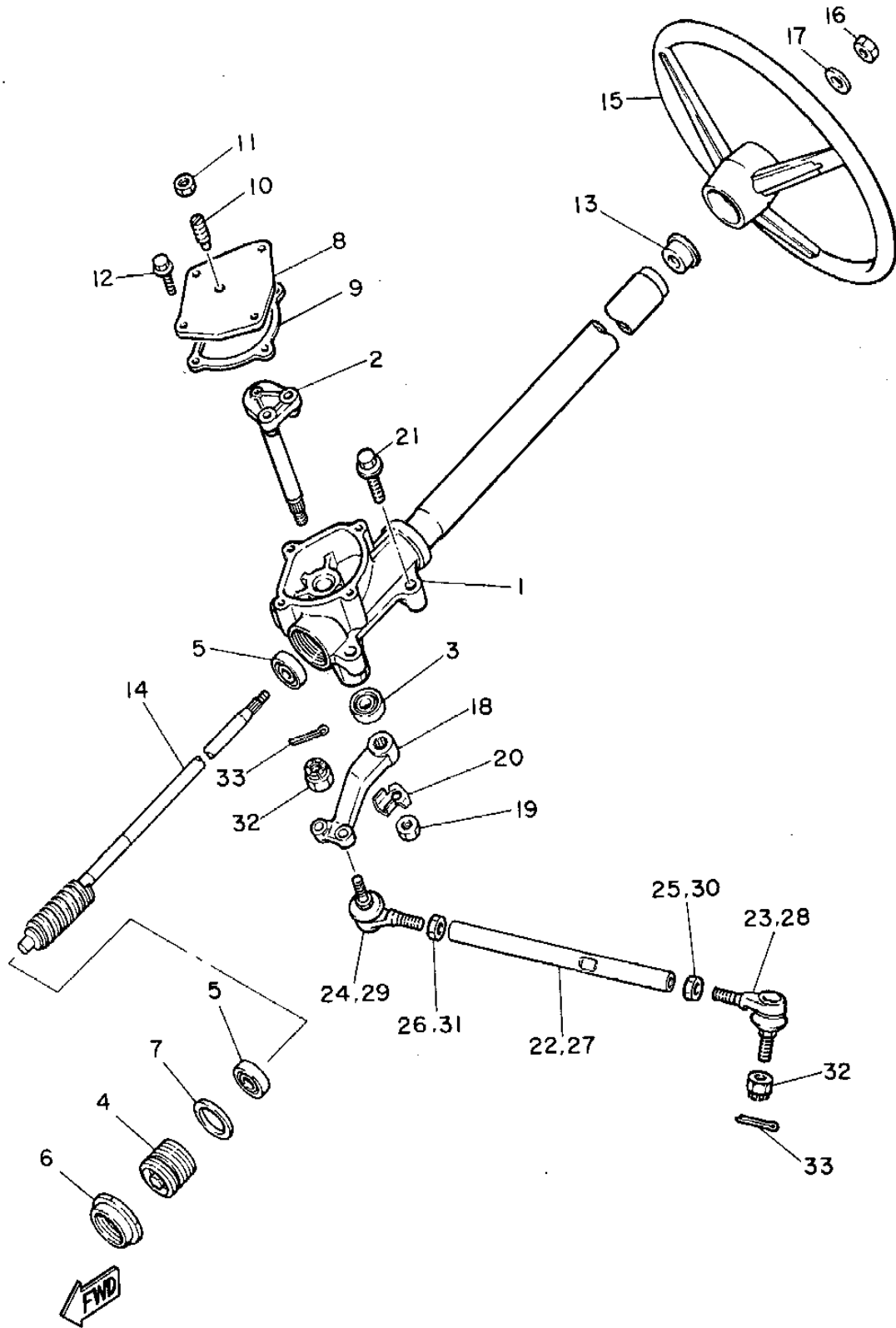

J41110-5040

Ref. No.	Part Number	Description	Qty	Remarks
1	JG5-F3811-00-00	COLUMN, STEERING	1	YPAD
2	J38-23816-00-00	ARM, PITMAN	1	
3	93102-22314-00	SEAL, OIL	1	
4	J55-F3876-00-00	BOLT	1	YPAD
5	93332-00010-00	BEARING	2	
6	J10-23877-00-00	NUT	1	
7	J10-23444-00-00	WASHER	1	
8	J55-23818-00-00	COVER, STEERING	1	
9	J38-23462-00-00	SEAL, STEERING (J38-23462-01-00)	1	
10	J10-23459-00-00	BOLT	1	
11	90170-08024-00	NUT, HEX.	1	
12	95811-06020-00	BOLT, FLANGE	4	
13	J38-23814-00-00	HOLDER, HANDLE UPPER	1	
14	J10-23840-00-00	STEERING SHAFT	1	
15	JF2-F3838-00-00	WHEEL, STEERING	1	YPAD
16	90185-12119-00	NUT, SELF-LOCKING	1	
17	92990-12200-00	WASHER, PLAIN	1	
18	J38-23826-01-00	ARM, IDLER	1	
19	95701-16300-00	NUT, FLANGE	1	
20	90215-16252-00	WASHER, TONGUE	1	
21	95811-10050-00	BOLT, FLANGE (95812-10050-00)	4	
22	J38-23831-02-00	ROD, TIE	1	
23	J38-23841-01-00	JOINT, UNIVERSAL 1	1	
24	J38-23845-01-00	JOINT, UNIVERSAL 2	1	
25	90170-12055-00	NUT	1	
26	90170-12054-00	NUT	1	
27	J38-23837-02-00	ROD, TIE 2	1	

CONTINUED ON NEXT FRAME ►

# STEERING

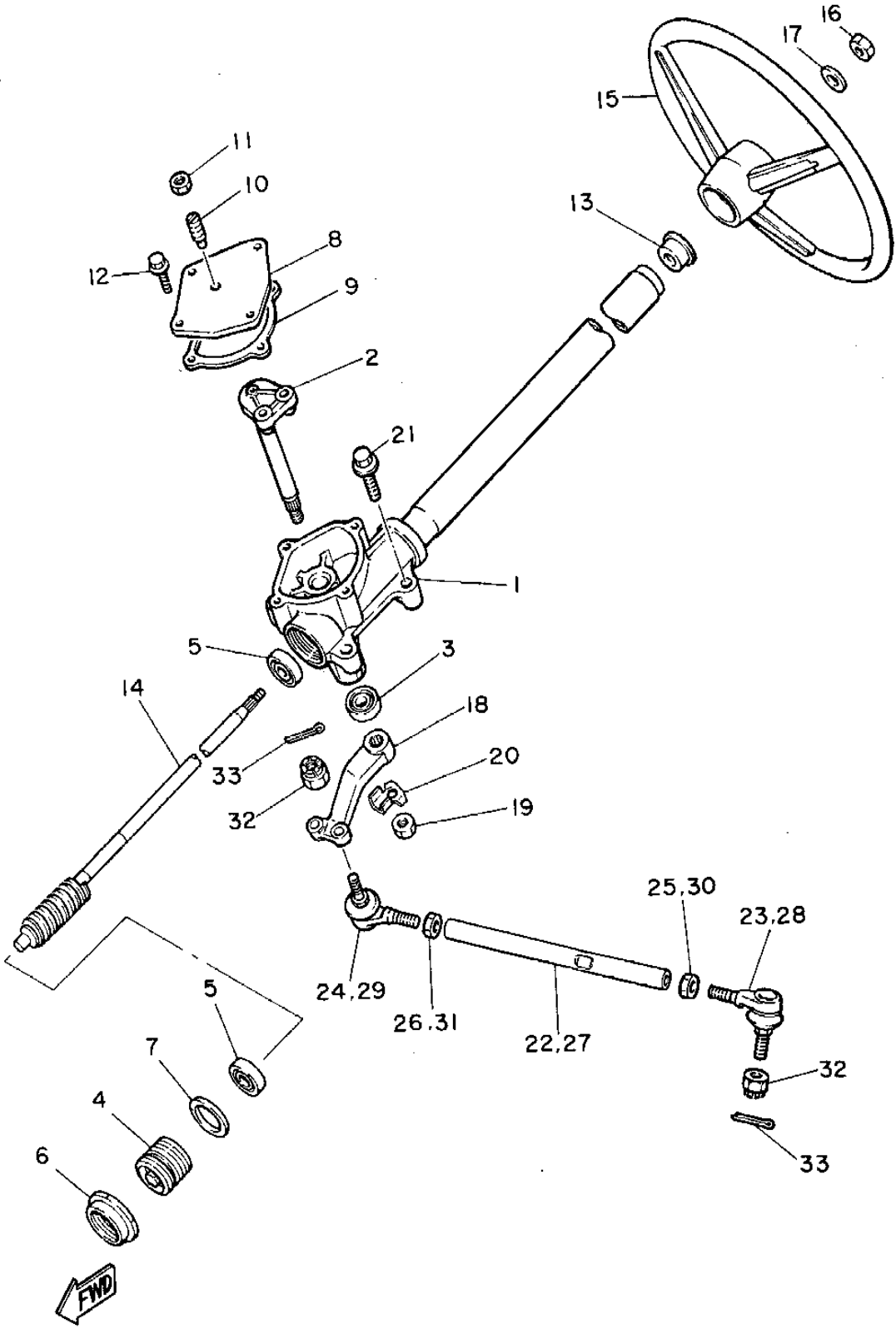

J41110-5040

Ref. No.	Part Number	Description	Qty	Remarks
28	J38-23841-01-00	JOINT, UNIVERSAL 1	1	
29	J38-23845-01-00	JOINT, UNIVERSAL 2	1	
30	90170-12055-00	NUT	1	
31	90170-12054-00	NUT	1	
32	95601-10100-00	NUT, U (95602-10100-00)	4	
33	91401-25020-00	PIN, COTTER	4	
	G9E-PARTS-BO-AR	ASSEMBLY, HARDWARE	9	OPTIONAL PART

# BRAKE 1

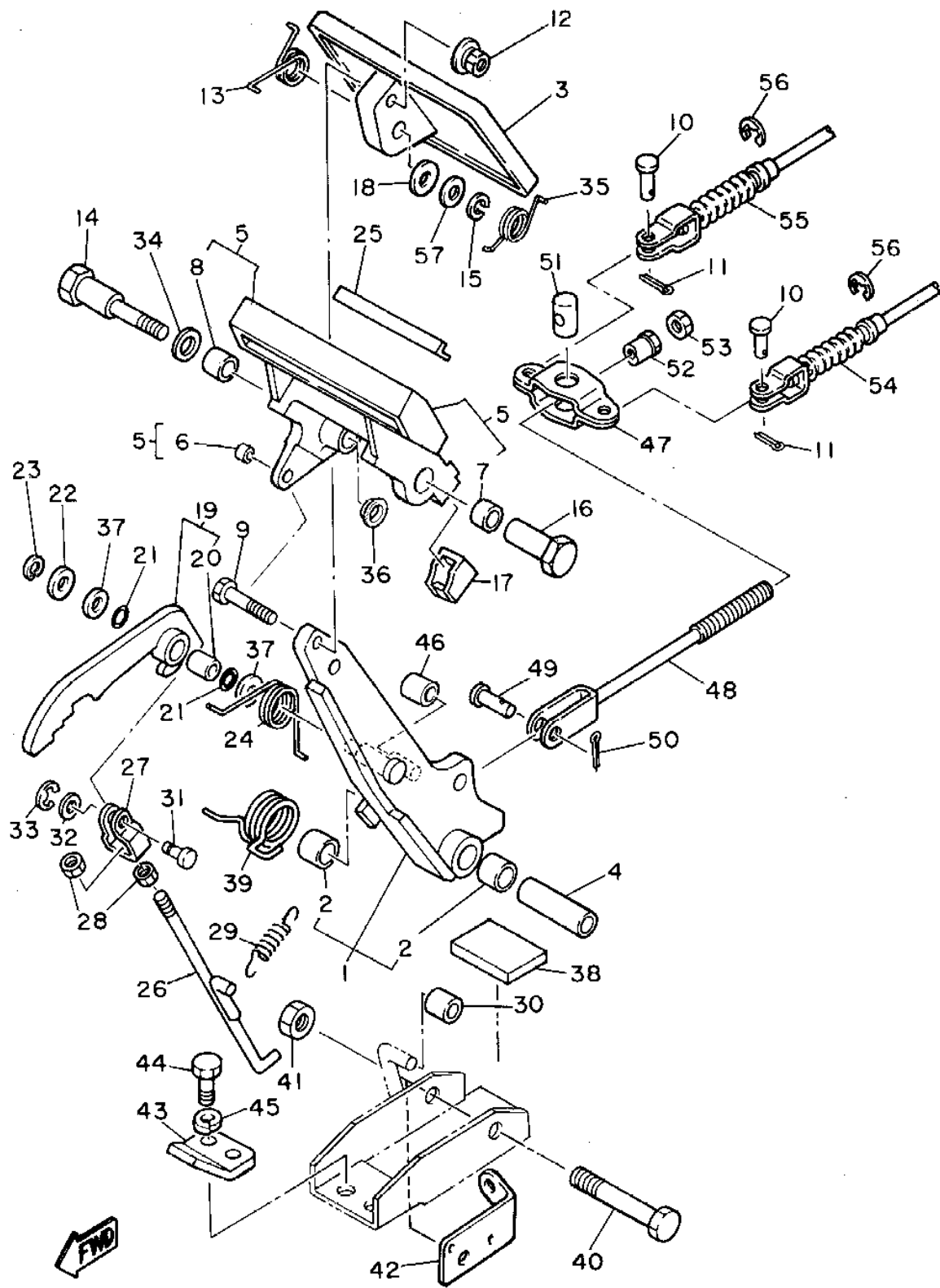

JG5100-1150

Ref. No.	Part Number	Description	Qty	Remarks
1	J17-27250-02-00	BRAKE ARM COMP. ....	1	
2	90384-14080-00	. BUSH, BIMETAL .....	2	
3	J10-27211-00-00	PEDAL, BRAKE .....	1	
4	90387-107F8-00	COLLAR .....	1	
5	J17-25670-01-00	PARKING PEDAL COMP. ....	1	
6	90384-05163-00	. BUSH, BIMETAL .....	1	
7	90384-12164-00	. BUSH, BIMETAL .....	1	
8	90380-12051-00	. BUSH, SOLID .....	1	
9	90101-06555-00	BOLT, HEX. ....	1	
10	91701-08018-00	PIN .....	4	
11	91490-25020-00	PIN, COTTER .....	4	
12	90179-07564-00	NUT .....	1	
13	90508-23542-00	SPRING, TORSION .....	1	
14	90109-08669-00	BOLT .....	1	
15	92902-08100-00	WASHER, SPRING .....	1	
16	90179-08378-00	NUT .....	1	
17	J17-25679-01-00	DAMPER .....	2	
18	92990-08200-00	WASHER, PLAIN .....	1	
19	J17-W2561-00-00	SECTOR, PARKING BRAKE ..	1	
20	90384-10162-00	BUSH, BIMETAL .....	1	
21	J17-27221-00-00	SEAL, SHAFT .....	2	
22	92990-10600-00	WASHER, PLATE .....	1	
23	99080-07600-00	CIRCLIP (E) .....	1	
24	90508-14548-00	SPRING, TORSION .....	1	
25	J17-25672-01-00	PAD, PARKING .....	1	
26	J17-27231-02-00	ROD, BRAKE .....	1	
27	J17-27232-00-00	END, ROD .....	1	
28	95380-06700-00	NUT .....	2	
29	90506-12277-00	SPRING, TENSION .....	1	

CONTINUED ON NEXT FRAME ►



# BRAKE 1

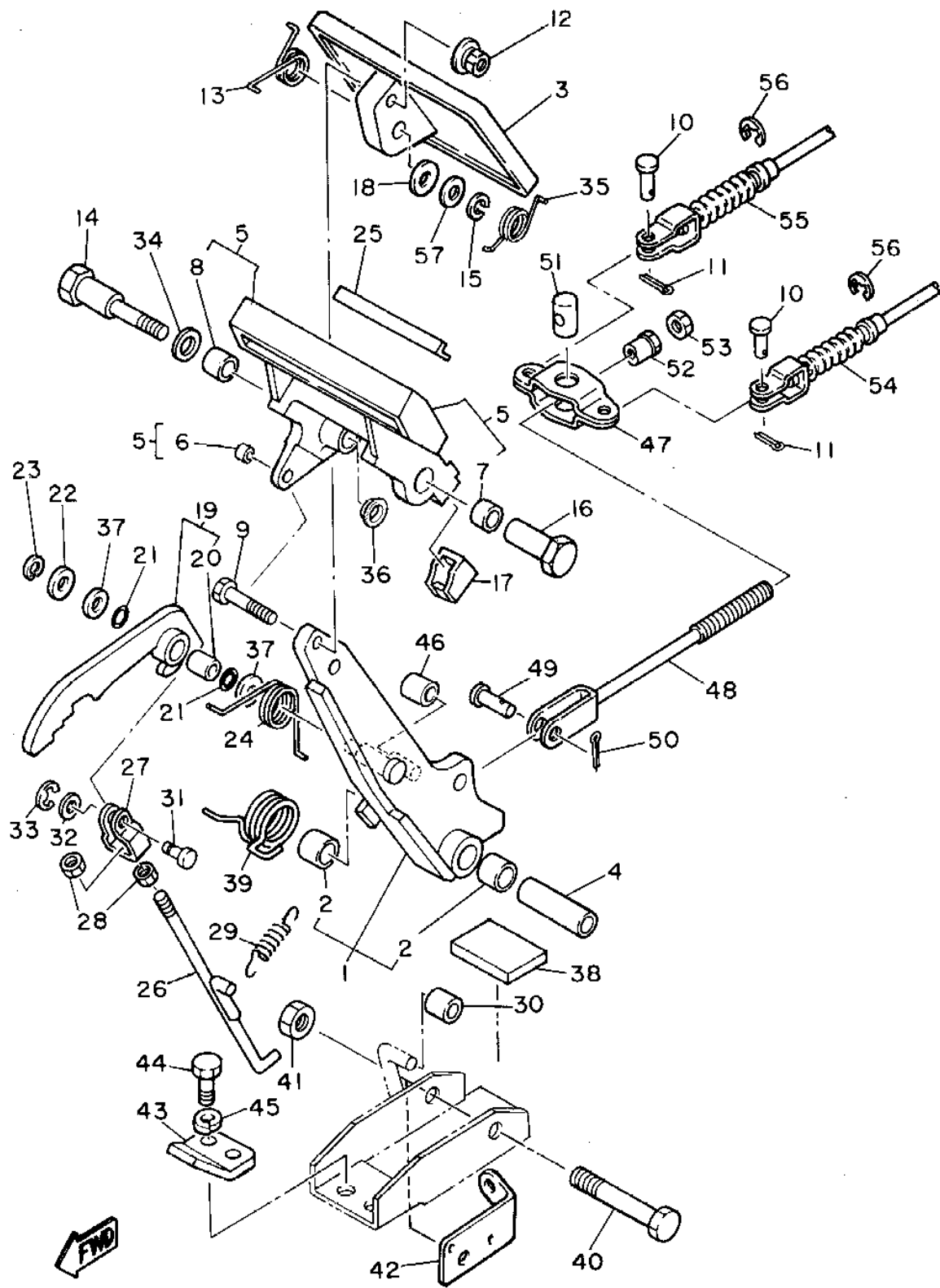

JG5100-1150

Ref. No.	Part Number	Description	Qty	Remarks
30	J17-25673-00-00	DAMPER, BRAKE	1	
31	J17-27228-00-00	PIN, LINK JOINT	1	
32	92901-05600-00	WASHER, PLATE	1	
33	99080-04600-00	CIRCLIP (E)	1	
34	90201-123F2-00	WASHER, PLAIN	1	
35	90508-26557-00	SPRING, TORSION	1	
36	90380-12105-00	BUSH, SOLID	1	
37	90201-104G8-00	WASHER, PLAIN	2	
38	J17-27245-00-00	PAD, BRAKE PEDAL	1	
39	90508-405A9-00	SPRING, TORSION	1	
40	90101-10447-00	BOLT, HEX.	1	
41	95601-10100-00	NUT, U (95602-10100-00)	1	
42	J55-2252M-00-00	BRACKET,	1	
43	J17-27246-00-00	NAIL, BRAKE	1	
44	97313-08020-00	BOLT, HEXAGON	2	
45	92902-08100-00	WASHER, SPRING	2	
46	J17-25673-00-00	DAMPER, BRAKE	1	
47	J10-25681-00-00	EQUALIZER, BRAKE	1	
48	J20-25685-00-00	ROD	1	
49	91701-10022-00	PIN	1	
50	91490-30020-00	PIN, COTTER	1	
51	90249-14129-00	PIN	1	
52	90179-08261-00	NUT	1	
53	95303-08700-00	NUT	1	
54	J56-F6341-00-00	CABLE, BRAKE	1	YPAD
55	J56-F6351-00-00	CABLE, BRAKE	1	YPAD
56	99001-09600-00	CIRCLIP	4	
57	J55-27226-00-00	WASHER, LINK	1	

# BRAKE 2

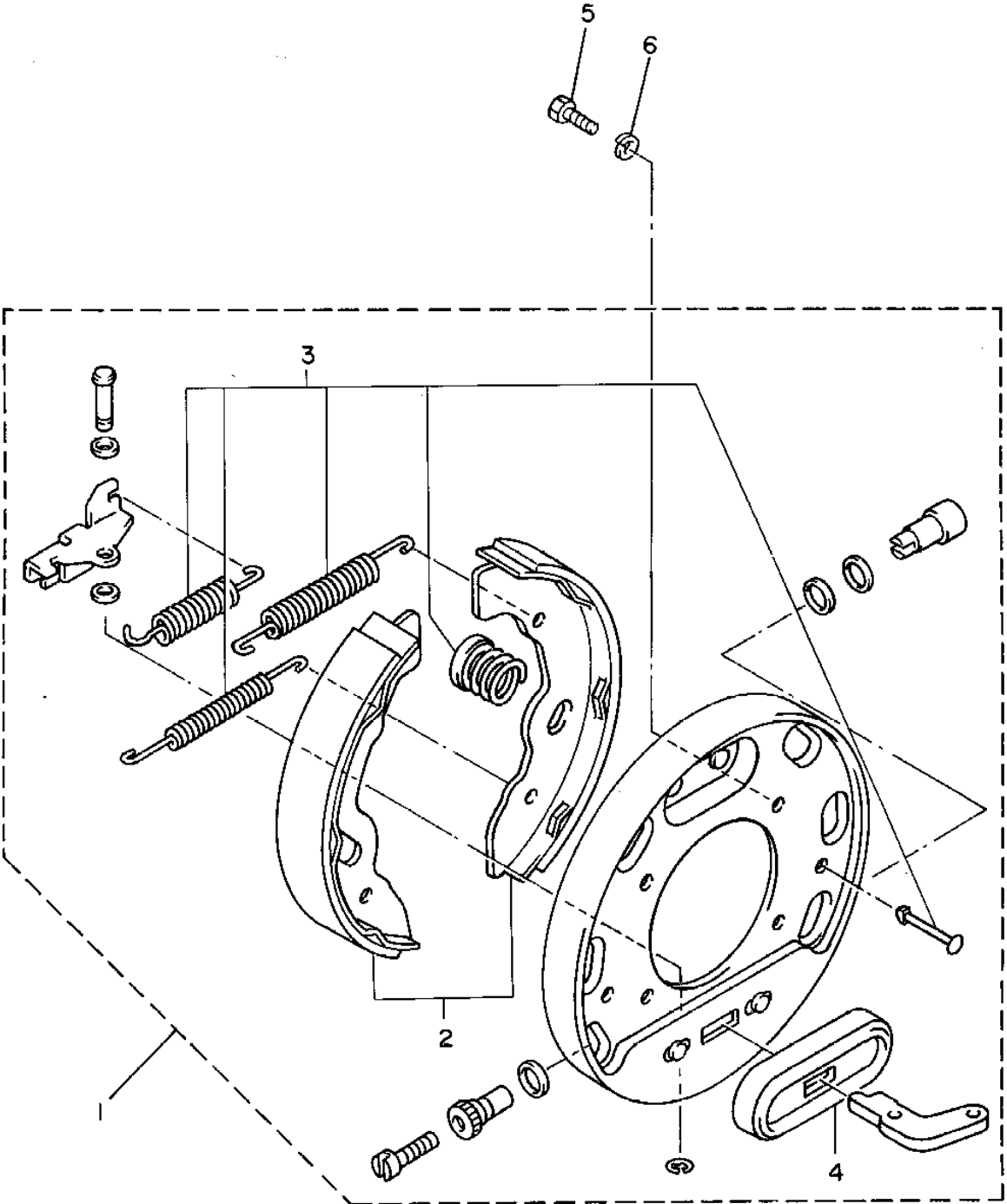

Ref. No.	Part Number	Description	Qty	Remarks
1	JG5-F7280-00-00	BACKING PLATE ASSEMBLY 1 (R.H)	2	YPAD
2	JG5-F5330-00-00	. BRAKE SHOE SET	1	
3	JG5-F819G-00-00	. REPAIR PARTS KIT	1	
4	JG5-F7286-00-00	. COVER, DUST	1	YPAD
5	97011-08016-00	BOLT	4	
6	92902-08100-00	WASHER, SPRING	4	



JG5100-3160

# BRAKE 3

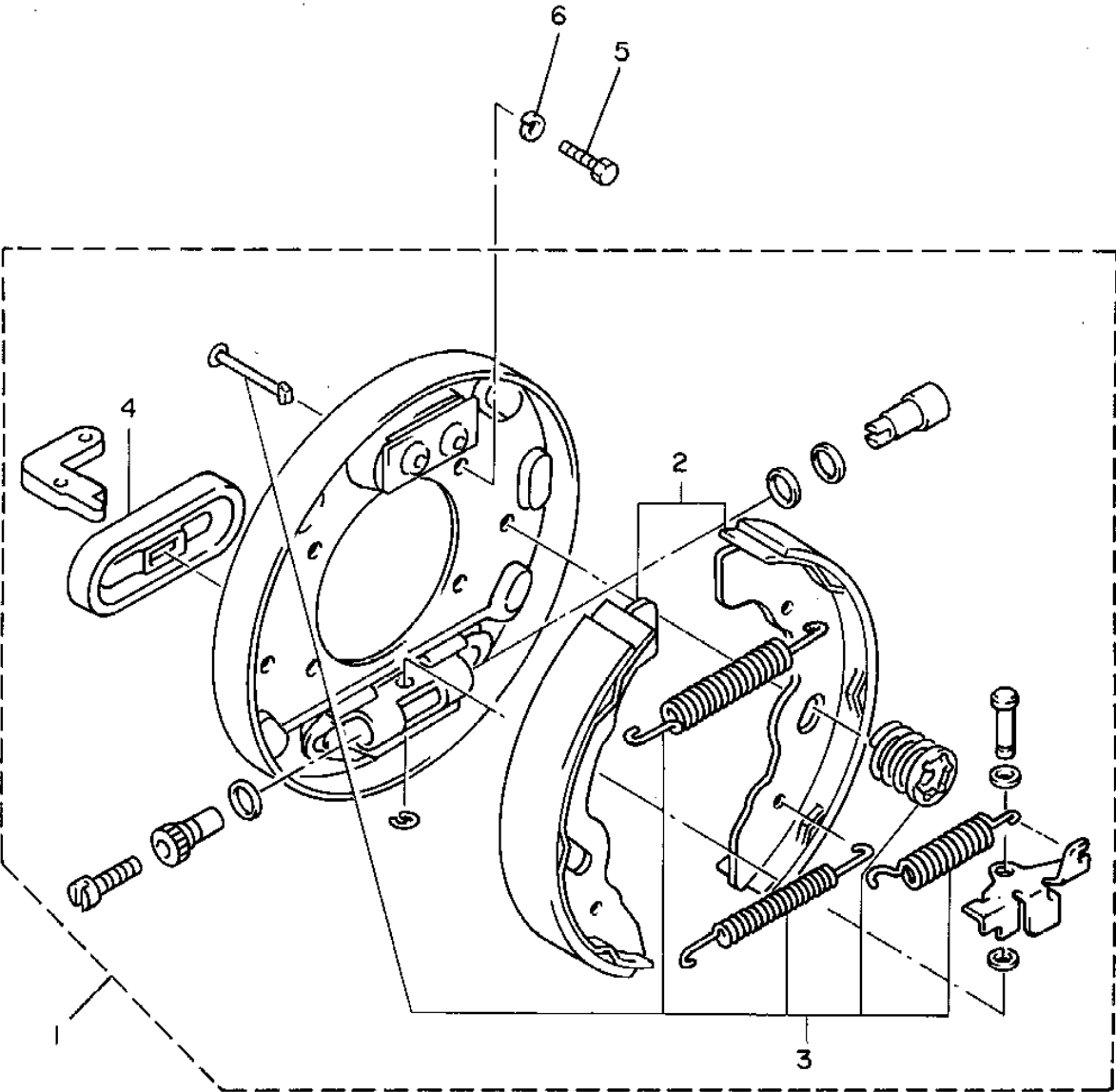

Ref. No.	Part Number	Description	Qty	Remarks
1	JG5-F7290-00-00	BACKING PLATE ASSEMBLY (L.H)	2	YPAD
2	JG5-F5330-00-00	. BRAKE SHOE SET	1	
3	JG5-F819G-00-00	. REPAIR PARTS KIT	1	
4	JG5-F7286-00-00	. COVER, DUST	1	YPAD
5	97011-08016-00	BOLT	4	
6	92902-08100-00	WASHER, SPRING	4	



JG5100-3170

# ACCELERATOR

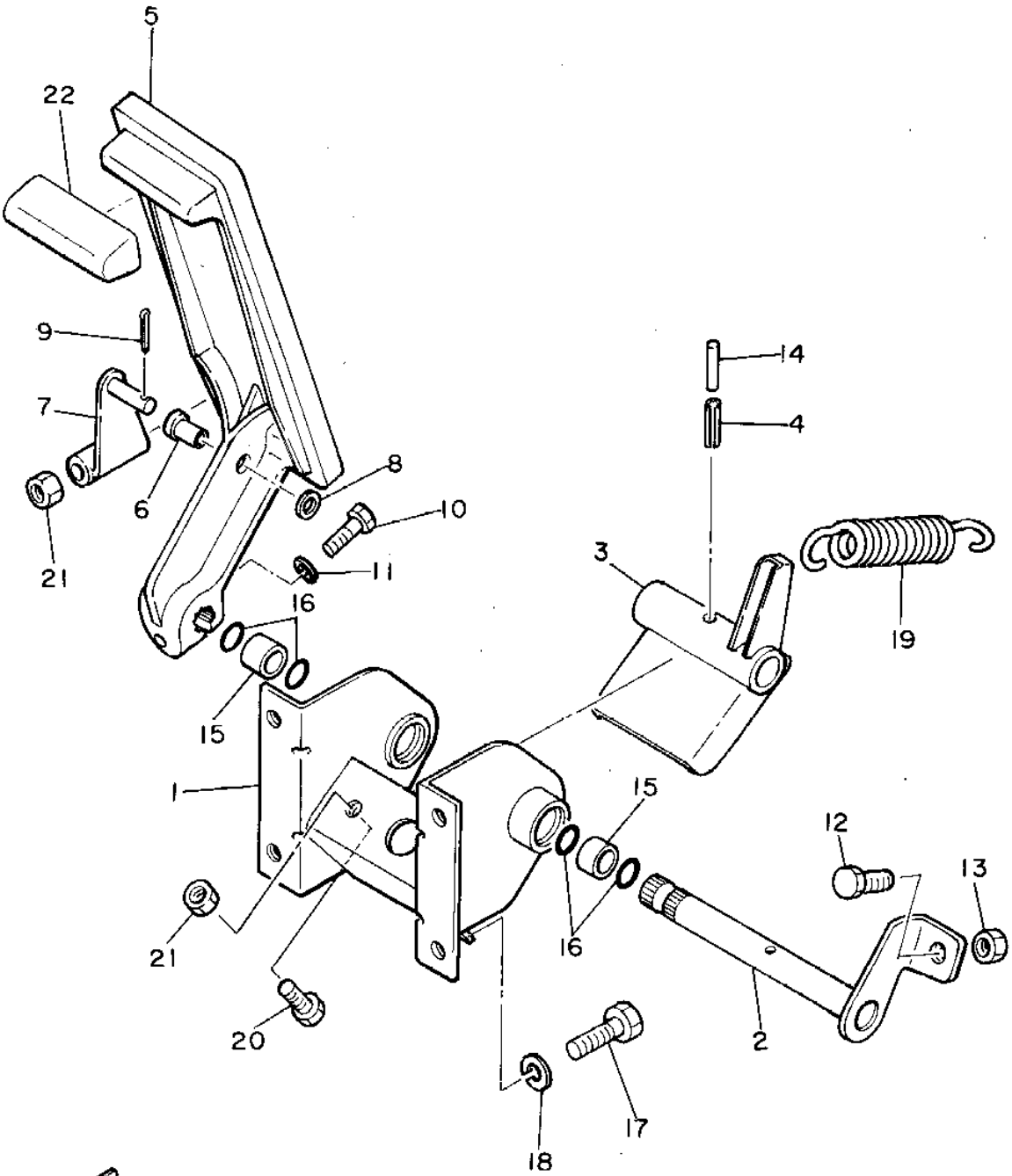

Ref. No.	Part Number	Description	Qty	Remarks
1	J41-27874-00-00	BRACKET, ACCELERATOR		
		PEDAL .....	1	
2	J17-27853-00-00	SHAFT, PEDAL 1 .....	1	
3	J22-27872-00-00	ARM, ACCELERATOR .....	1	
4	91609-60028-00	PIN, SPRING .....	1	
5	JF3-27871-00-00	PEDAL, ACCELERATOR .....	1	
6	90381-06033-00	BUSH, SOLID .....	1	
7	J14-27815-00-00	LEVER, CRANK .....	1	
8	92990-06600-00	WASHER, PLATE .....	1	
9	91490-20020-00	PIN, COTTER .....	1	
10	97011-06025-00	BOLT (97001-06025) .....	1	
11	92995-06100-00	WASHER, SPRING .....	1	
12	90106-08040-00	BOLT, RD. HEX .....	1	
13	95303-08700-00	NUT .....	1	
14	91609-35028-00	PIN, SPRING .....	1	
15	90384-14080-00	BUSH, BIMETAL .....	2	
16	93210-14104-00	O-RING .....	4	
17	97011-06016-00	BOLT .....	4	
18	92995-06100-00	WASHER, SPRING .....	4	
19	90506-26282-00	SPRING, TENSION .....	1	
20	97011-06025-00	BOLT (97001-06025) .....	1	
21	95380-06700-00	NUT .....	1	
22	JF2-27854-00-00	COVER, PEDAL .....	1	



JH7100-3080

# TRANSMISSION 1

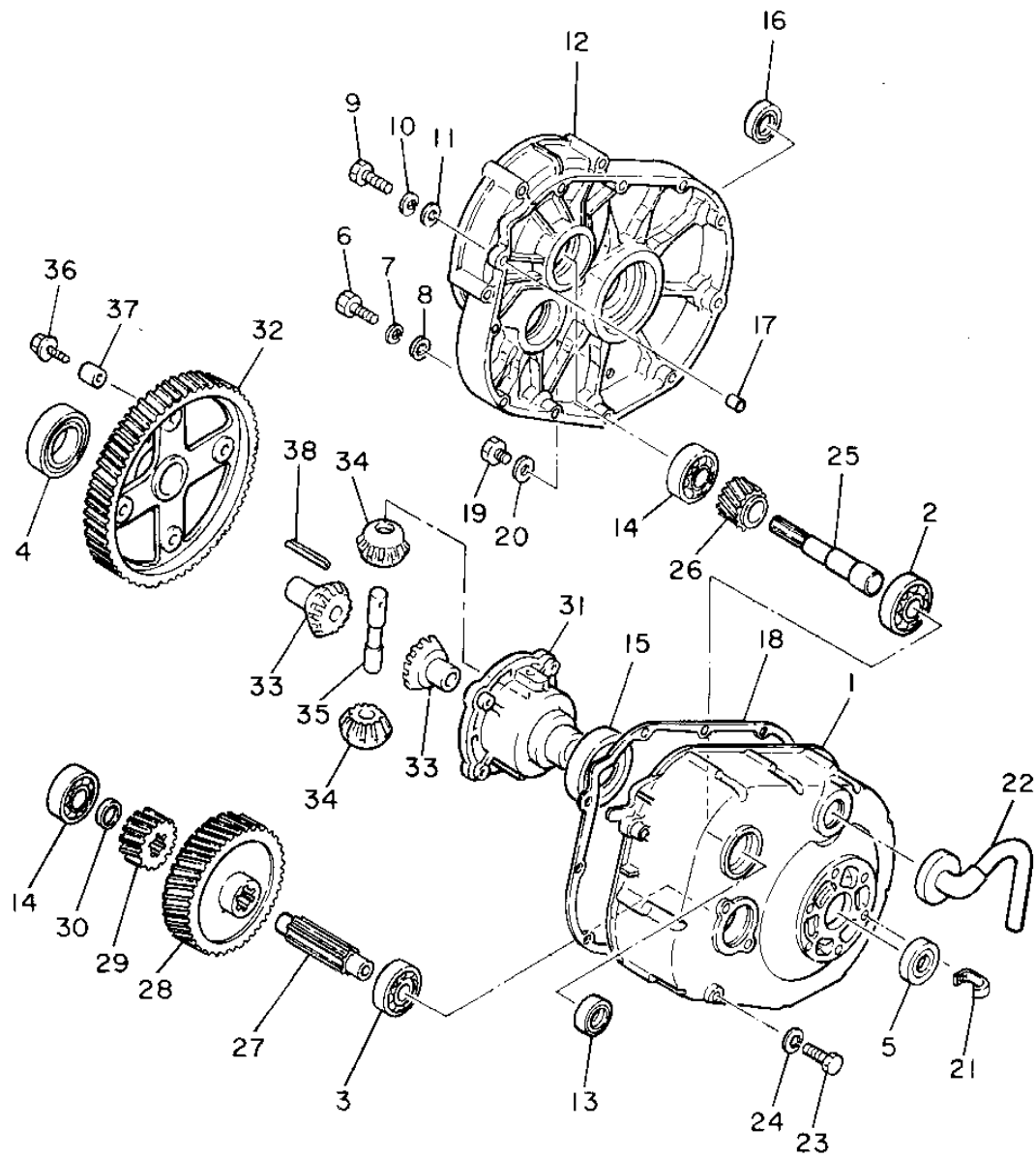

Ref. No.	Part Number	Description	Qty	Remarks
1	J14-46311-00-00	CASE, TRANSMISSION 1	1	SEE NOTE
2	93306-20541-00	BEARING (B6205)	1	SEE NOTE
3	93306-20421-00	BEARING	1	SEE NOTE
4	93306-00804-00	BEARING	1	SEE NOTE
5	93102-22189-00	OIL SEAL	1	SEE NOTE
6	97021-08035-00	BOLT	9	SEE NOTE
7	92990-08100-00	WASHER	9	SEE NOTE
8	92901-08600-00	WASHER	9	SEE NOTE
9	97021-08045-00	BOLT	2	SEE NOTE
10	92990-08100-00	WASHER	2	SEE NOTE
11	92901-08600-00	WASHER	2	SEE NOTE
12	J14-46312-02-00	CASE, TRANSMISSION 2	1	SEE NOTE
13	93102-20143-00	OIL SEAL	1	SEE NOTE
14	93306-20421-00	BEARING	2	SEE NOTE
15	93306-00804-00	BEARING	1	SEE NOTE
16	93102-22189-00	OIL SEAL	1	SEE NOTE
17	99510-12016-00	PIN, DOWEL	2	SEE NOTE
18	J10-46319-01-00	GASKET	1	SEE NOTE
19	90340-14036-00	PLUG, STRAIGHT SCRW	2	SEE NOTE
20	90430-14043-00	GASKET	2	SEE NOTE
21	90465-06100-00	CLAMP	1	SEE NOTE
22	835-47559-00-00	CAP 2	1	SEE NOTE
23	97011-10020-00	BOLT	2	SEE NOTE
24	92901-10100-00	WASHER, SPRING	2	SEE NOTE
25	J14-46321-01-00	SHAFT, INPUT	1	SEE NOTE
26	J56-46331-00-00	GEAR, INPUT 1	1	SEE NOTE
27	J10-46351-00-00	SHAFT, COUNTER	1	SEE NOTE
28	J56-46361-00-00	GEAR, COUNTER 1	1	SEE NOTE
29	J17-46362-00-00	GEAR, COUNTER 2	1	SEE NOTE

CONTINUED ON NEXT FRAME ►



JH7100-3090

# TRANSMISSION 1

Ref. No.	Part Number	Description	Qty	Remarks
----------	-------------	-------------	-----	---------

30	90201-20272-00	WASHER, PLATE .....	1	SEE NOTE
31	J38-46411-01-00	CASE, DIFFERENTIAL .....	1	SEE NOTE
32	J41-46421-00-00	GEAR, RING .....	1	SEE NOTE
33	J38-46414-00-00	GEAR, DIFFERENTIAL SIDE ..	2	SEE NOTE
34	J38-46415-00-00	PINION, DIFFERENTIAL .....	2	SEE NOTE
35	J38-46417-02-00	PIN, DIFFERENTIAL .....	1	SEE NOTE
36	90105-08390-00	BOLT, WASHER BASED .....	4	SEE NOTE
37	91812-16001-00	PIN, DOWEL .....	2	SEE NOTE
38	91609-40040-00	PIN, SPRING .....	1	SEE NOTE

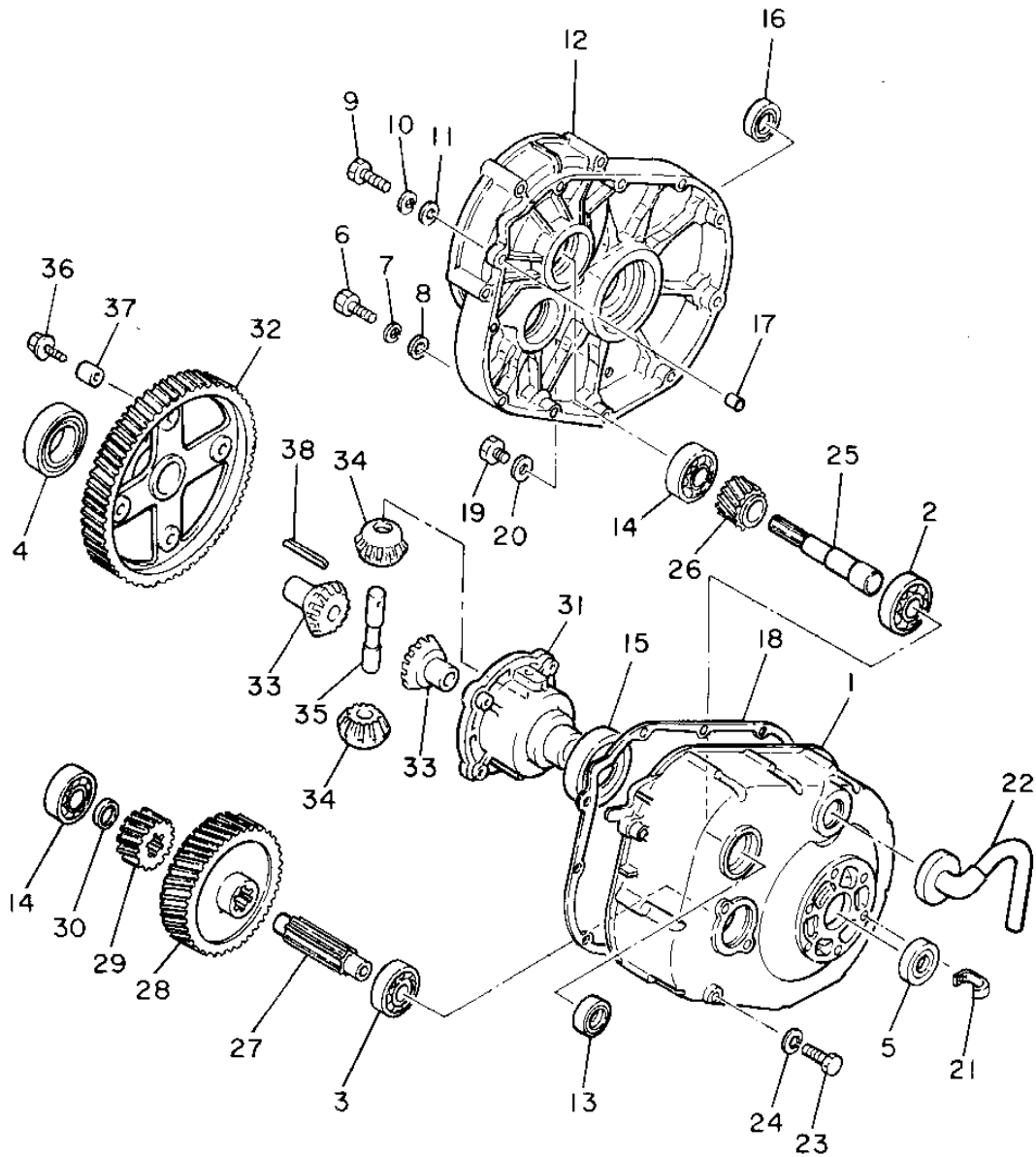

JH7100-3090

# TRANSAXLE ASSEMBLY

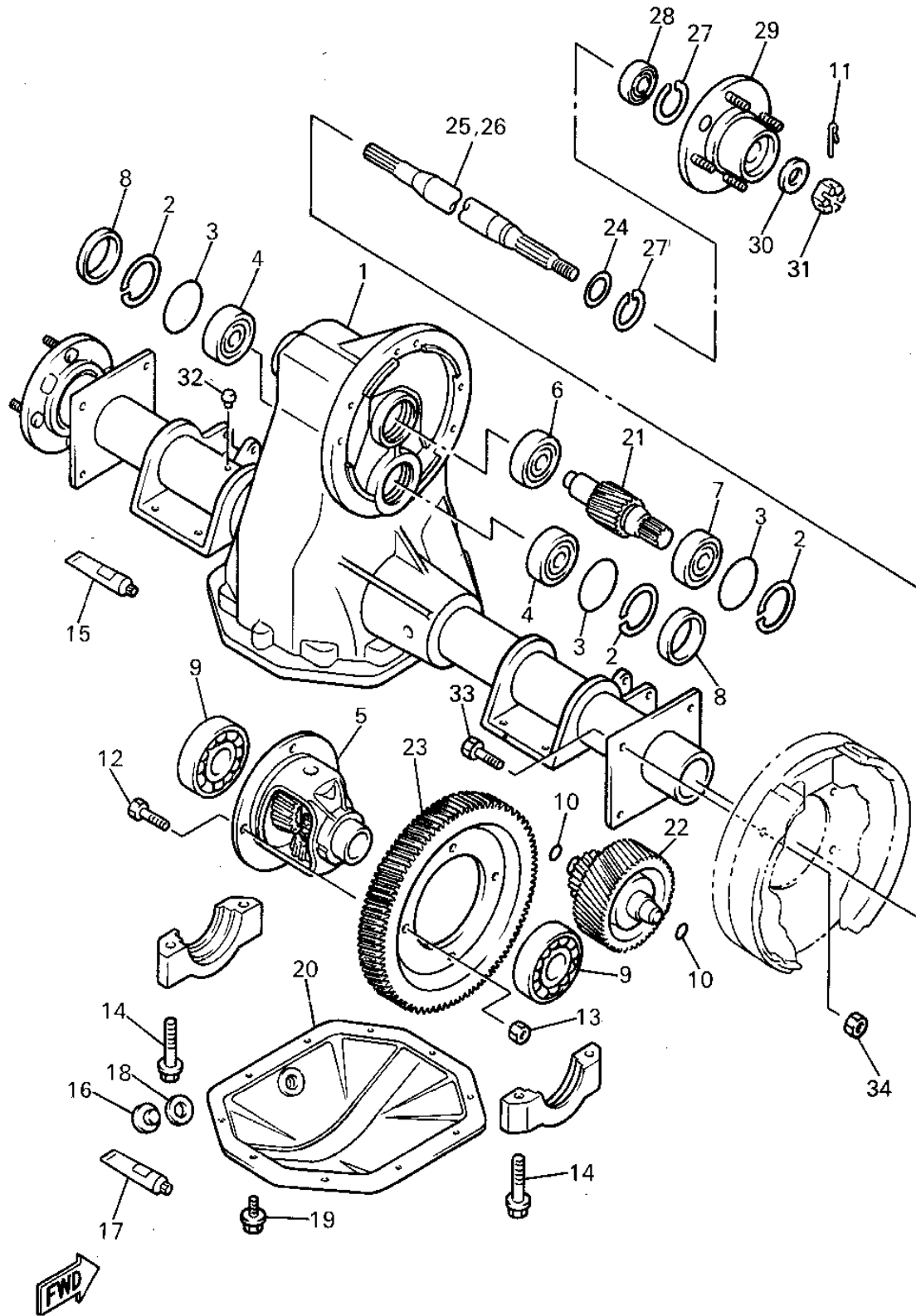

Ref. No.	Part Number	Description	Qty	Remarks
1	JH7-G6310-00-00	CASE ASSEMBLY	1	SEE NOTE
2	93420-50804-00	CIRCLIP	3	SEE NOTE
3	93210-478B8-00	RING	3	SEE NOTE
4	93306-303Y6-00	BEARING	2	SEE NOTE
5	JH7-G6410-00-00	DIFFERENTIAL ASSEMBLY	1	SEE NOTE
6	93306-203X1-00	BEARING	1	SEE NOTE
7	93306-005Y1-00	BEARING	1	SEE NOTE
8	JH7-G3396-00-00	PLUG, BLIND	2	SEE NOTE
9	93306-007Y0-00	BEARING	2	SEE NOTE
10	93210-148B9-00	O-RING	2	SEE NOTE
11	91490-25030-00	PIN, COTTER	2	SEE NOTE
12	90101-10854-00	BOLT, HEX.	4	SEE NOTE
13	90170-10840-00	NUT, HEX.	4	SEE NOTE
14	90105-10840-00	BOLT, FLANGE	4	SEE NOTE
15	ACC-11001-31-00	SEALANT 2 (JH7-G6137-00-00)	1	SEE NOTE
16	JH7-G5341-00-00	PLUG, DRAIN	1	SEE NOTE
17	ACC-11001-05-01	SEALANT 1 (JH7-G6136-00-00)	1	SEE NOTE
18	90201-158E0-00	WASHER, PLATE	1	SEE NOTE
19	90101-08856-00	BOLT, HEX.	10	SEE NOTE
20	JH7-G6312-00-00	CASE, TRANSMISSION 2	1	SEE NOTE
21	JH7-G6321-00-00	SHAFT, INPUT	1	SEE NOTE
22	JH7-G6350-00-00	COUNTER GEAR	1	SEE NOTE
23	JH7-G6421-00-00	GEAR, RING	1	SEE NOTE
24	93101-24822-00	SEAL, OIL	2	SEE NOTE
25	JH7-G6512-00-00	SHAFT, REAR AXLE 2 (RH)	1	SEE NOTE
26	JH7-G6511-00-00	SHAFT, REAR AXLE 1 (LH)	1	SEE NOTE
27	93420-44805-00	CIRCLIP	4	SEE NOTE
28	93306-004X5-00	BEARING	2	SEE NOTE
29	JH7-G6514-00-00	HUB, REAR AXLE	2	SEE NOTE

CONTINUED ON NEXT FRAME ►

JH7110-3220

# TRANSAXLE ASSEMBLY

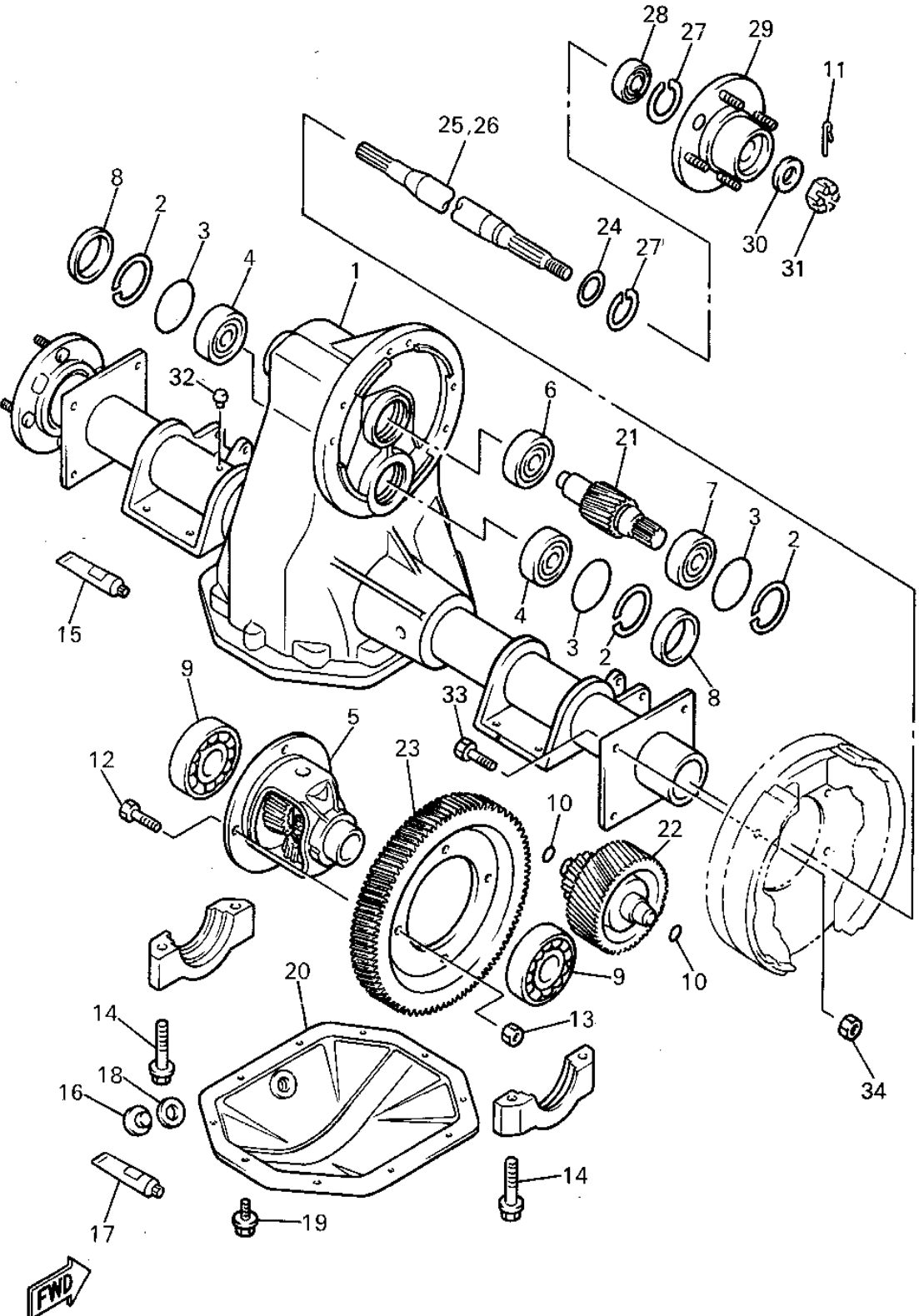

Ref. No.	Part Number	Description	Qty	Remarks
30	90201-198E1-00	WASHER .....	2	SEE NOTE
31	90171-16813-00	NUT .....	2	SEE NOTE
32	JH7-G5619-00-00	CAP .....	1	SEE NOTE
33	90101-08855-00	BOLT, HEX. ....	8	SEE NOTE
34	90170-08841-00	NUT, HEX. ....	8	SEE NOTE

JH7110-3220



# REAR AXLE - WHEEL

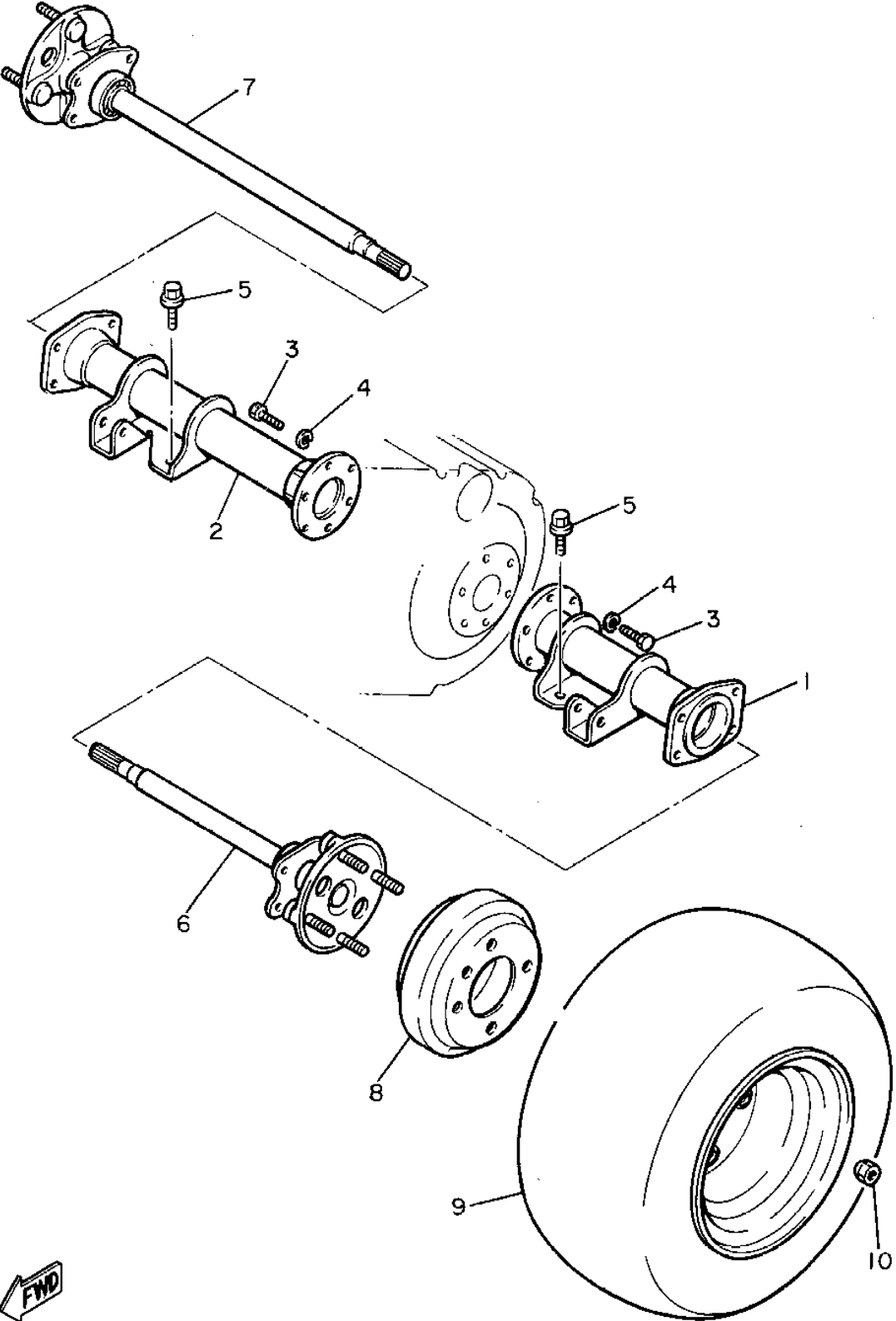

Ref. No.	Part Number	Description	Qty	Remarks
1	J41-46540-01-00	REAR AXLE HOUSING COMP.	1	SEE NOTE
2	J41-46550-01-00	REAR AXLE HOUSING COMP. 2	1	SEE NOTE
3	97017-08025-00	BOLT	12	SEE NOTE
4	92902-08100-00	WASHER, SPRING	12	SEE NOTE
5	95811-10020-00	BOLT, FLANGE (95822-10020-00)	8	SEE NOTE
6	J41-46510-00-00	REAR AXLE SHAFT COMP. ...	1	SEE NOTE
7	J41-46520-00-00	REAR AXLE SHAFT COMP. 2	1	SEE NOTE
8	J55-G6521-00-00	DRUM	2	SEE NOTE
9	JG5-F5100-30-00	FRONT WHEEL ASSEMBLY (JG5-F5100-30-00)	2	SEE NOTE
10	90179-12262-00	NUT	8	SEE NOTE
6-1	90114-12004-00	. BOLT, RIBBED NECK	4	SEE NOTE
7-1	90114-12004-00	. BOLT, RIBBED NECK	4	SEE NOTE



J41100-7090

# REAR WHEEL

Ref. No.	Part Number	Description	Qty	Remarks
1	J55-G6521-00-00	DRUM .....	2	YPAD
2	JG5-F5100-10-00	REAR WHEEL ASSEMBLY ...	2	
3	90179-12262-00	NUT .....	8	
4	J17-25118-00-00	COVER, HUB DUST .....	2	

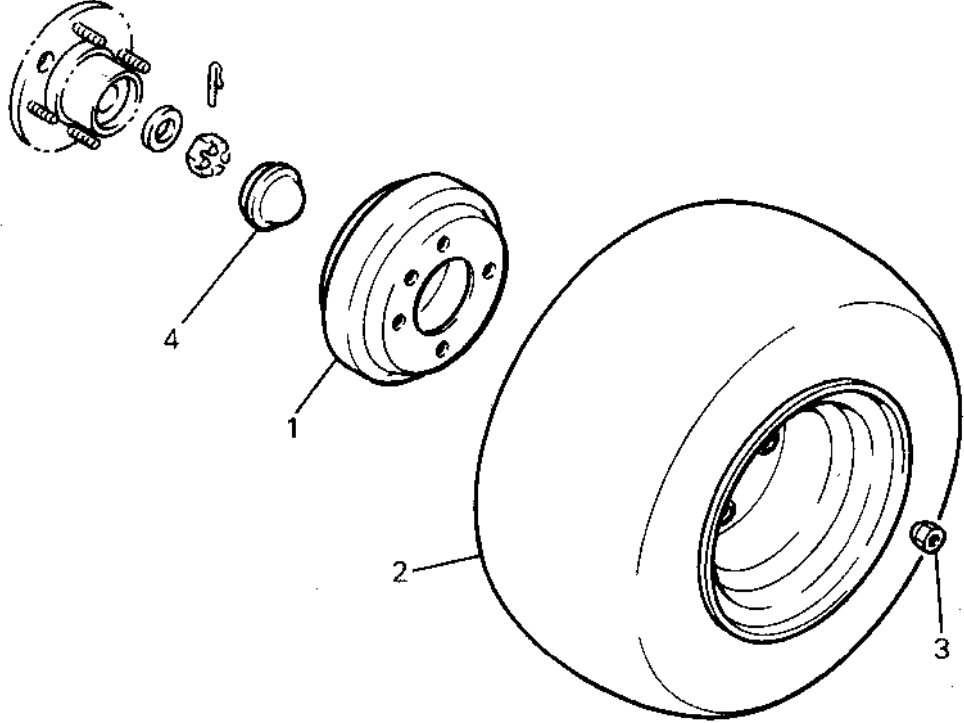

JH7100-4100

# BUMPER

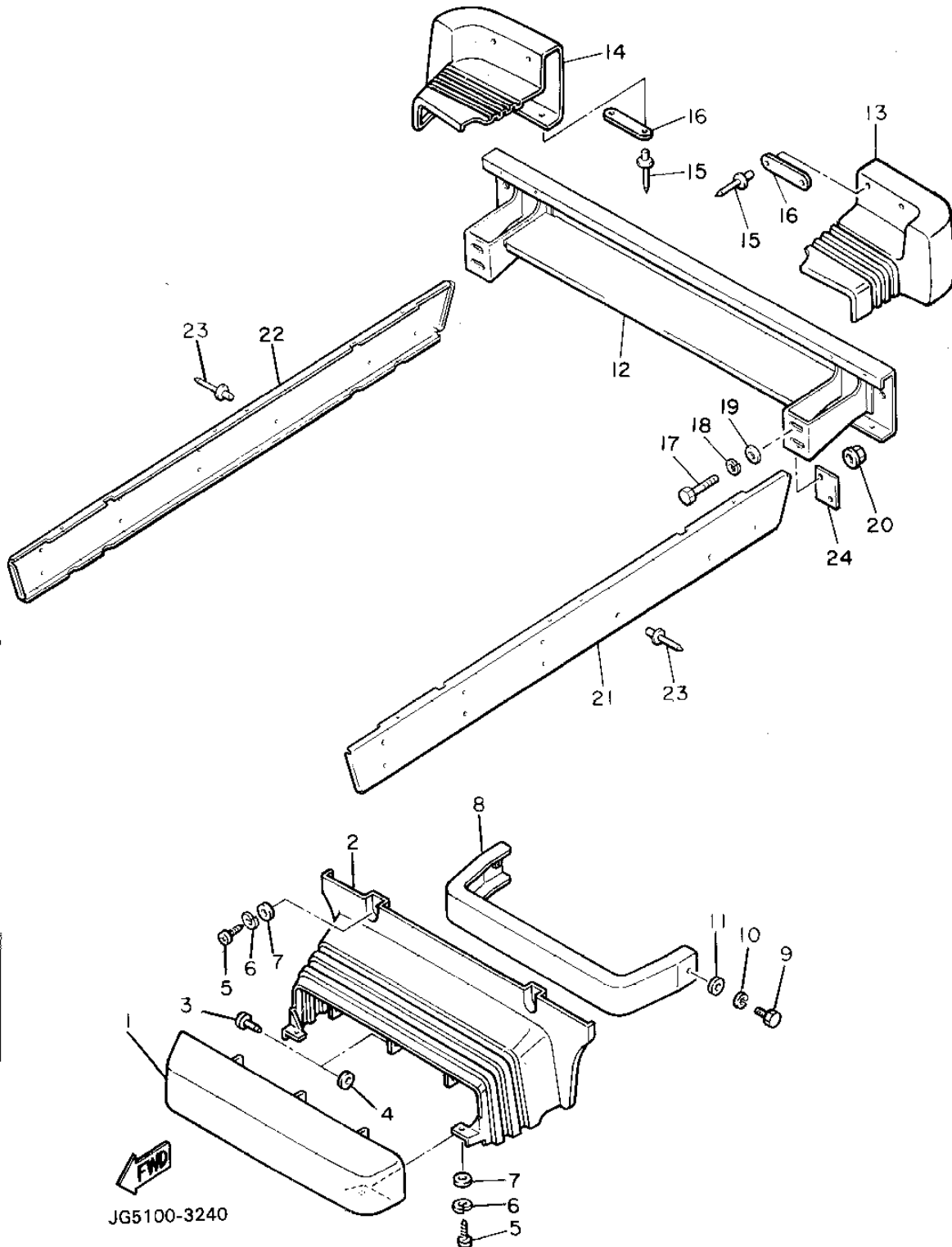

Ref. No.	Part Number	Description	Qty	Remarks
1	J55-K8162-00-00	PAD, FRONT BUMPER	1	YPAD
2	J55-K8163-00-00	COVER, BUMPER	1	YPAD
3	90269-06028-00	RIVET	3	
4	90201-076J4-00	WASHER, PLATE	3	
5	98506-05020-00	SCREW, PAN HEAD	4	
6	92906-05100-00	WASHER, SPRING	4	
7	90201-05033-00	WASHER, PLATE	4	
8	J55-K7511-00-00	BUMPER, FRONT 1	1	YPAD
9	97011-08016-00	BOLT	2	
10	92902-08100-00	WASHER, SPRING	2	
11	92990-08600-00	WASHER, PLATE	2	
12	JG5-K8107-00-00	BUMPER SUB-ASSEMBLY, REAR	1	YPAD
13	J55-K8167-00-00	BUMPER, RUBBER 1	1	YPAD
14	J55-K8168-00-00	BUMPER, RUBBER 2	1	YPAD
15	90267-40077-00	RIVET, BLIND	8	
16	J17-77525-00-00	WASHER 1	4	
17	97026-08050-00	BOLT	4	
18	92906-08100-00	WASHER, SPRING	4	
19	92906-08600-00	WASHER	4	
20	95706-08500-00	NUT, flange	4	
21	JG5-K8183-00-00	PLATE, SIDE SILL (L.H)	1	YPAD
22	JG5-K8184-00-00	PLATE, SIDE SILL (R.H)	1	YPAD
23	90267-48828-00	RIVET, BLIND	18	
24	G9E-PARTS-BO-AR JG5-K7527-00-00	ASSEMBLY, HARDWARE PLATE, BACK UP	9 2	OPTIONAL PART YPAD

JG5100-3240

# BODY

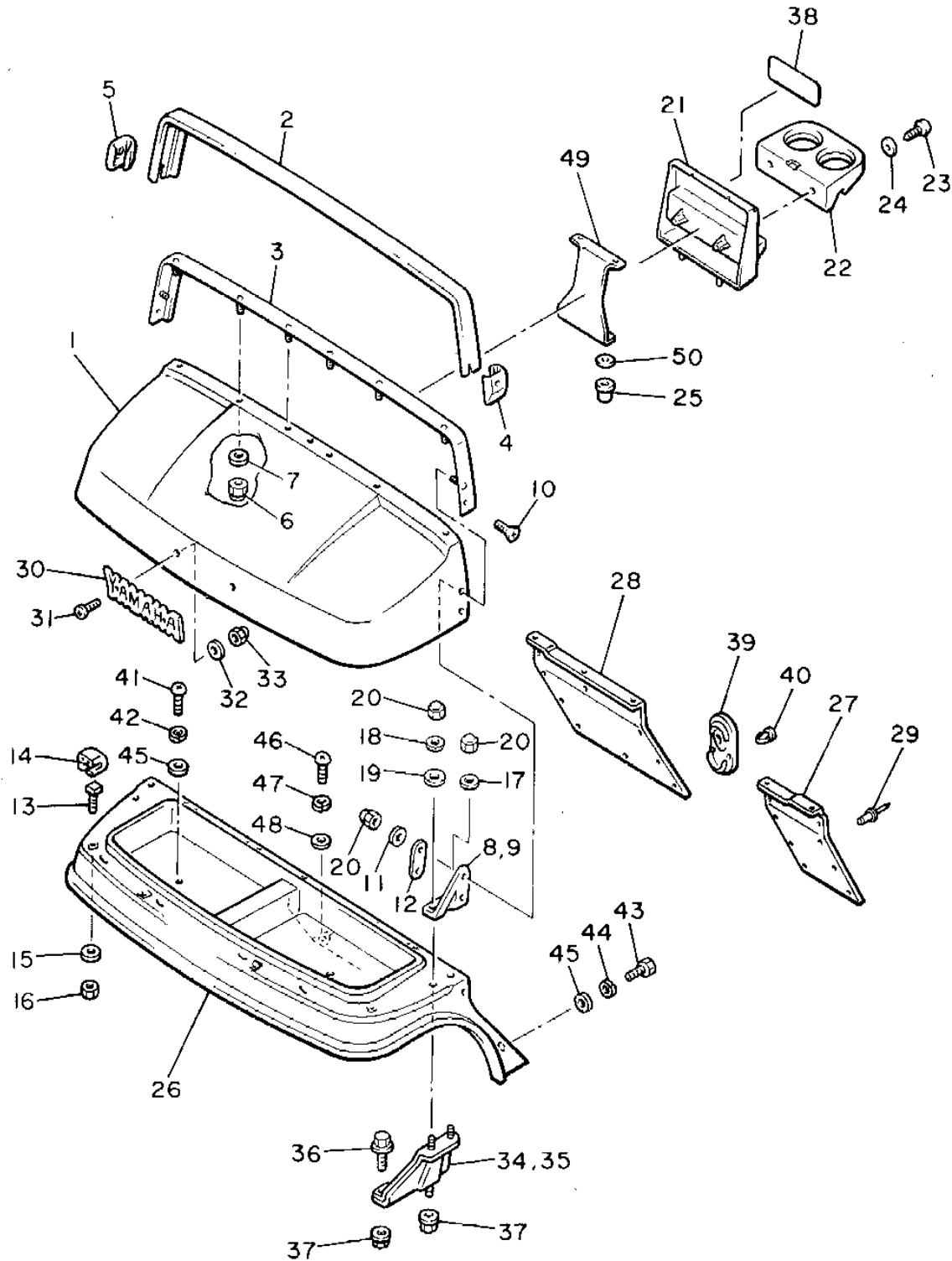

Ref. No.	Part Number	Description	Qty	Remarks
1	J55-K8116-00-00	COWL, FRONT UPPER	1	YPAD
2	JG5-K811V-00-00	PROTECTOR 1	1	YPAD
3	JG5-K8261-01-00	PLATE, BODY PROTECT 1 (JG5-K8261-00-00)	1	YPAD
4	JG5-K818E-00-00	CAP, PROTECTOR END 1	1	YPAD
5	JG5-K818F-00-00	CAP, PROTECTOR END 2	1	YPAD
6	95601-06200-00	NUT, U FLANGE	6	
7	90201-06059-00	WASHER, PLATE	6	
8	JG5-K811E-00-00	STAY, UPPER COWL (LH)	1	
9	JG5-K811F-00-00	STAY, UPPER COWL (RH)	1	
10	90151-06803-00	SCREW, COUNTERSUNK	2	YPAD
11	92990-06200-00	WASHER	4	
12	JG5-K8117-00-00	PLATE 1	2	YPAD
13	J38-7811G-00-00	BOLT, COWL FITTING	4	
14	J38-7811H-00-00	RETAINER, COWL FITTING	4	
15	90201-065F3-00	WASHER, PLATE	4	
16	95601-06100-00	NUT, U	4	
17	90201-062G3-00	WASHER, PLATE	2	
18	92990-06200-00	WASHER	2	
19	90202-06172-00	WASHER, PLATE	2	
20	J55-K811B-00-00	NUT, CAP	8	YPAD
21	JG5-K835G-00-00	HOUSING, HOLDER	1	YPAD
22	JF2-K835E-00-00	HOLDER, BEVERAGE	1	YPAD
23	97702-60130-00	SCREW, TAPPING	2	
24	90201-060A3-00	WASHER, PLATE	2	
25	90480-12355-00	GROMMET	2	
26	JG5-K8115-00-00	COWL, FRONT	1	YPAD
27	JG5-K8231-00-00	MAT, MAIN FLOOR 1	1	YPAD
28	JG5-K8232-00-00	MAT, MAIN FLOOR 2	1	YPAD

CONTINUED ON NEXT FRAME ►



JH7100-3120

# BODY

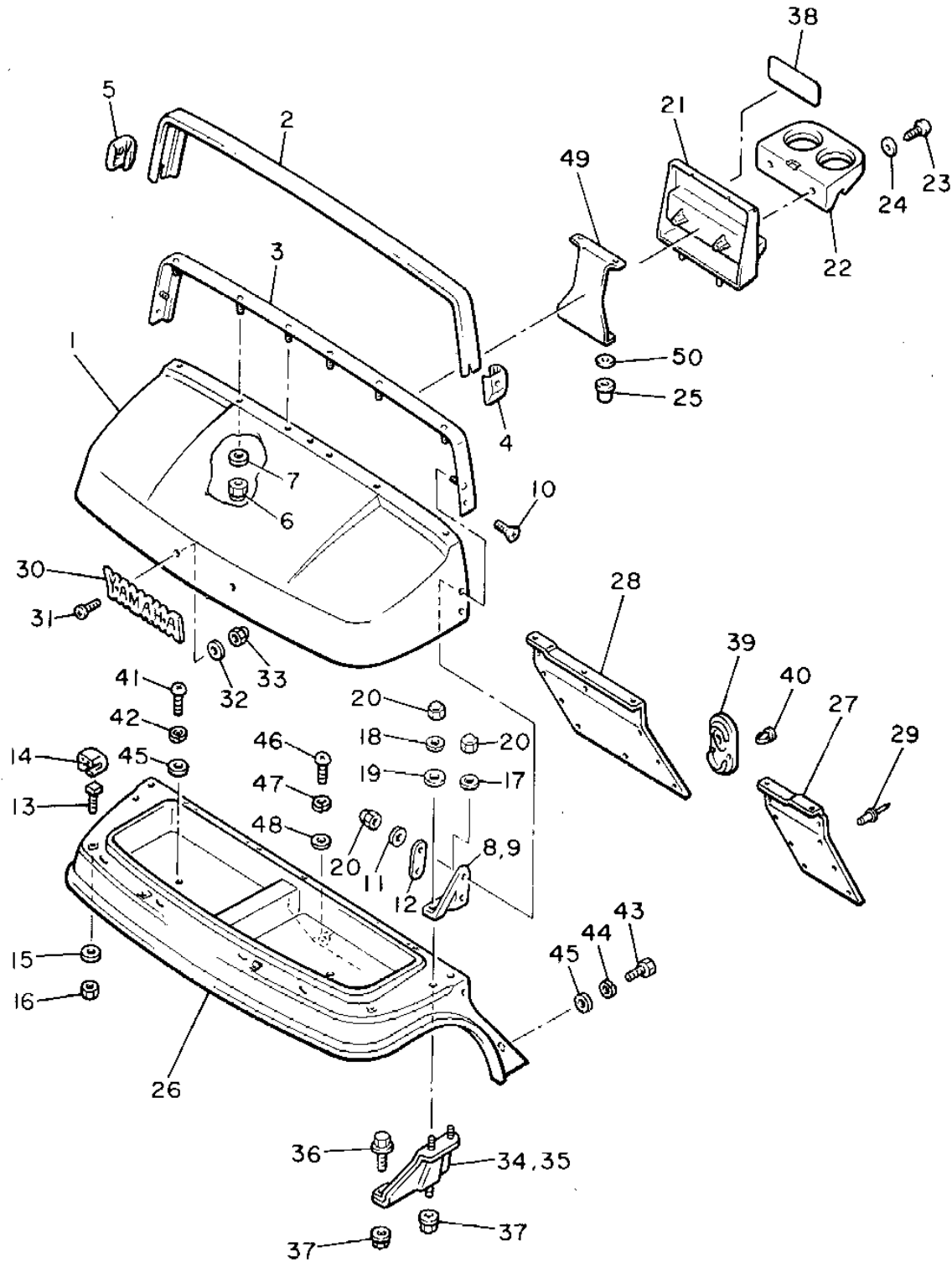

Ref. No.	Part Number	Description	Qty	Remarks
29	90267-63047-00	RIVET, BLIND	16	
30	J38-24161-00-00	EMBLEM 1	1	
31	90152-04015-00	SCREW, COUNTERSUNK	2	
32	92906-04200-00	WASHER, PLAIN	2	
33	95606-04100-00	NUT, U	2	
34	J38-7812E-01-00	SUPPORT, UPPER COWL (L.H)	1	
35	J38-7812F-01-00	SUPPORT, UPPER COWL (R.H)	1	
36	95811-08016-00	BOLT, FLANGE	2	
37	95701-08500-00	NUT, FLANGE	4	
38	J50-77768-00-00	LABEL, WARNING 2	1	UR
39	J38-78273-00-00	COVER, HOLE	1	
40	90269-11042-00	RIVET	2	
41	98580-06020-00	SCREW	2	
42	92995-06100-00	WASHER, SPRING	2	
43	97595-06520-00	BOLT, WITH WASHER	2	
44	92995-06100-00	WASHER, SPRING	2	
45	90201-067M9-00	WASHER, PLATE	4	
46	98580-06020-00	SCREW	1	
47	92995-06100-00	WASHER, SPRING	1	
48	90201-06049-00	WASHER, PLATE	1	
49	JG5-K834A-00-00	REING., HOLDER	1	YPAD
50	90183-06011-00	NUT, SPRING	2	



JH7100-3120

# BODY 2

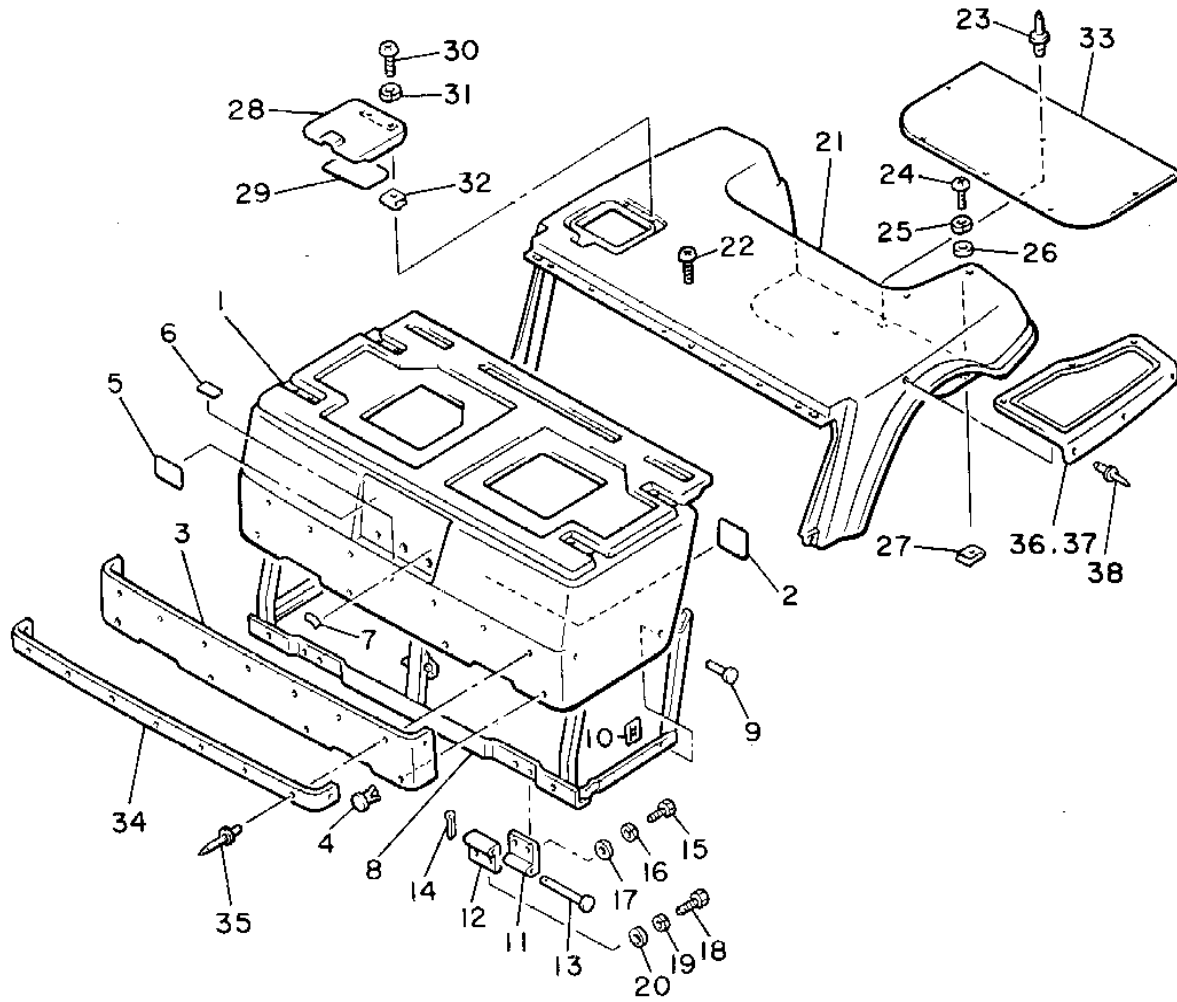

Ref. No.	Part Number	Description	Qty	Remarks
1	J55-K8141-00-00	PANEL, INTERMEDIATE BODY	1	YPAD
2	JH7-K7765-00-00	LABEL, WARNING 5	1	UR YPAD
3	JG5-K814N-00-00	PLATE, ORNAMENT	1	YPAD
4	90267-63047-00	RIVET, BLIND	4	
5	J41-77458-10-00	LABEL, WARNING (J41-77458-00-00)	1	UR
6	J38-77741-10-00	INDICATOR 1	1	UR
7	J38-77742-00-00	INDICATOR 2	1	
8	JG6-K8121-00-00	REINFORCEMENT 1	1	YPAD
9	90338-06169-00	PLUG	2	
10	90183-06011-00	NUT, SPRING	2	
11	J55-K8143-00-00	HINGE, INTERMEDIATE BODY 1	2	YPAD
12	J55-K8144-00-00	HINGE, INTERMEDIATE BODY 2	2	YPAD
13	91790-06125-00	PIN, CLEVIS	2	
14	91490-20015-00	PIN, COTTER	2	
15	97013-06012-00	BOLT	4	
16	92995-06100-00	WASHER, SPRING	4	
17	92990-06600-00	WASHER, PLATE	4	
18	97011-06020-00	BOLT	4	
19	92995-06100-00	WASHER, SPRING	4	
20	92990-06600-00	WASHER, PLATE	4	
21	J55-K8142-00-00	PANEL, REAR BODY	1	YPAD
22	95811-06020-00	BOLT, FLANGE	3	
23	90201-06M08-00	WASHER, PLATE	2	
24	92580-06020-00	SCREW, PAN HEAD	2	
25	92995-06100-00	WASHER, SPRING	2	
26	90201-065F3-00	WASHER, PLATE	2	
27	90183-06028-00	NUT, SPRING	2	

  
JH7100-3130

CONTINUED ON NEXT FRAME ►

# BODY 2

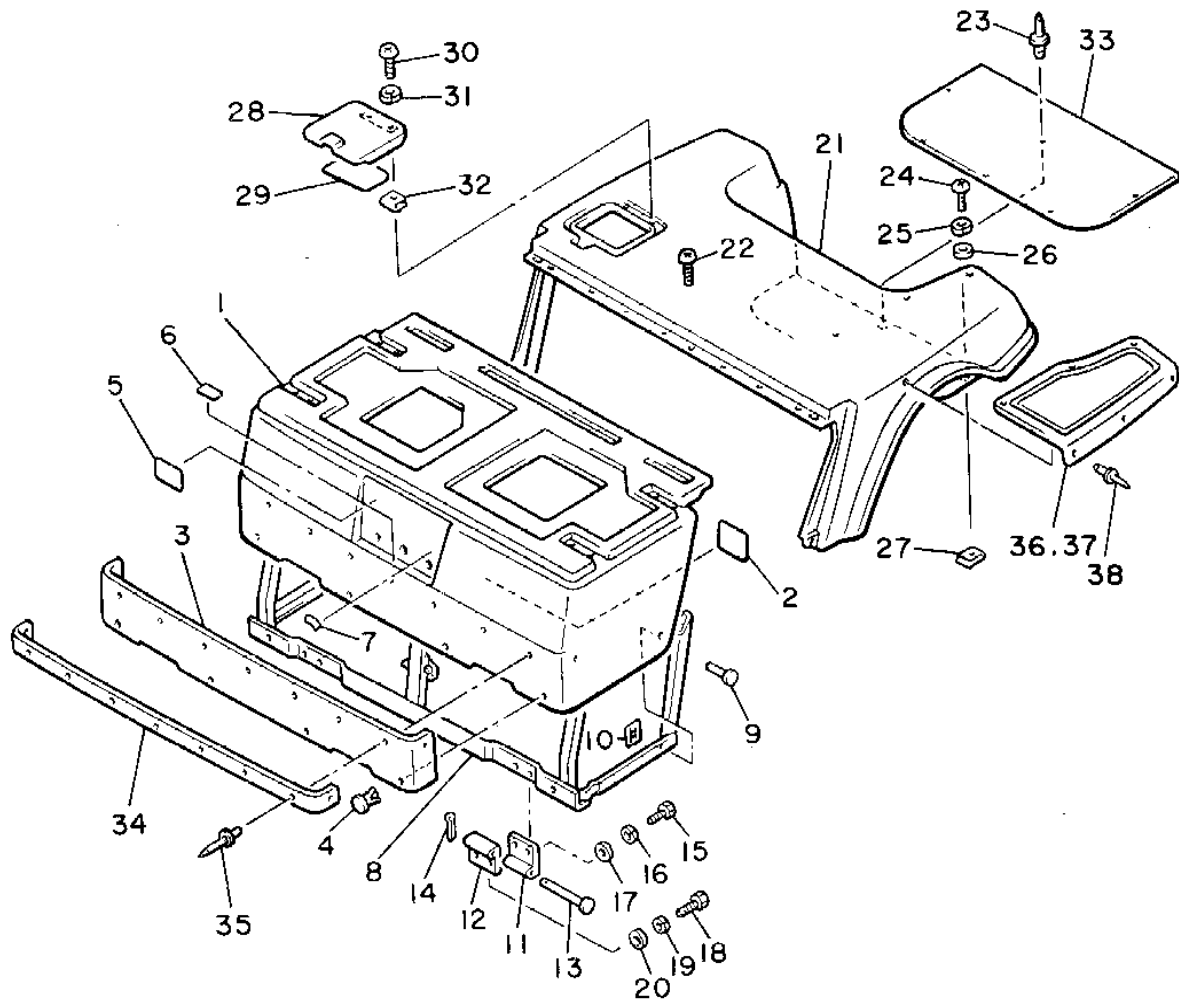

Ref. No.	Part Number	Description	Qty	Remarks
28	J55-K8272-00-00	COVER, FUEL INLET	1	YPAD
29	J51-77764-00-00	LABEL, WARNING 4	1	UR
30	98511-04012-00	SCREW, PAN HEAD	2	
31	92901-04100-00	WASHER, SPRING	2	
32	J38-78276-00-00	NUT, INLET FITTING	2	
33	JG5-K8241-00-00	MAT, REAR FLOOR	1	YPAD
34	JG5-K824E-00-00	TRIM, REAR BODY (L.H)	1	YPAD
35	90267-41137-00	RIVET, BLIND	9	
36	J55-K8243-00-00	MAT, REAR BODY SIDE (LH)	1	YPAD
37	J55-K8244-00-00	MAT, REAR BODY SIDE (RH)	1	YPAD
38	90267-63047-00	RIVET, BLIND	12	
	G9E-PARTS-BO-AR	ASSEMBLY, HARDWARE	9	OPTIONAL PART



JH7100-3130

# BODY FITTING

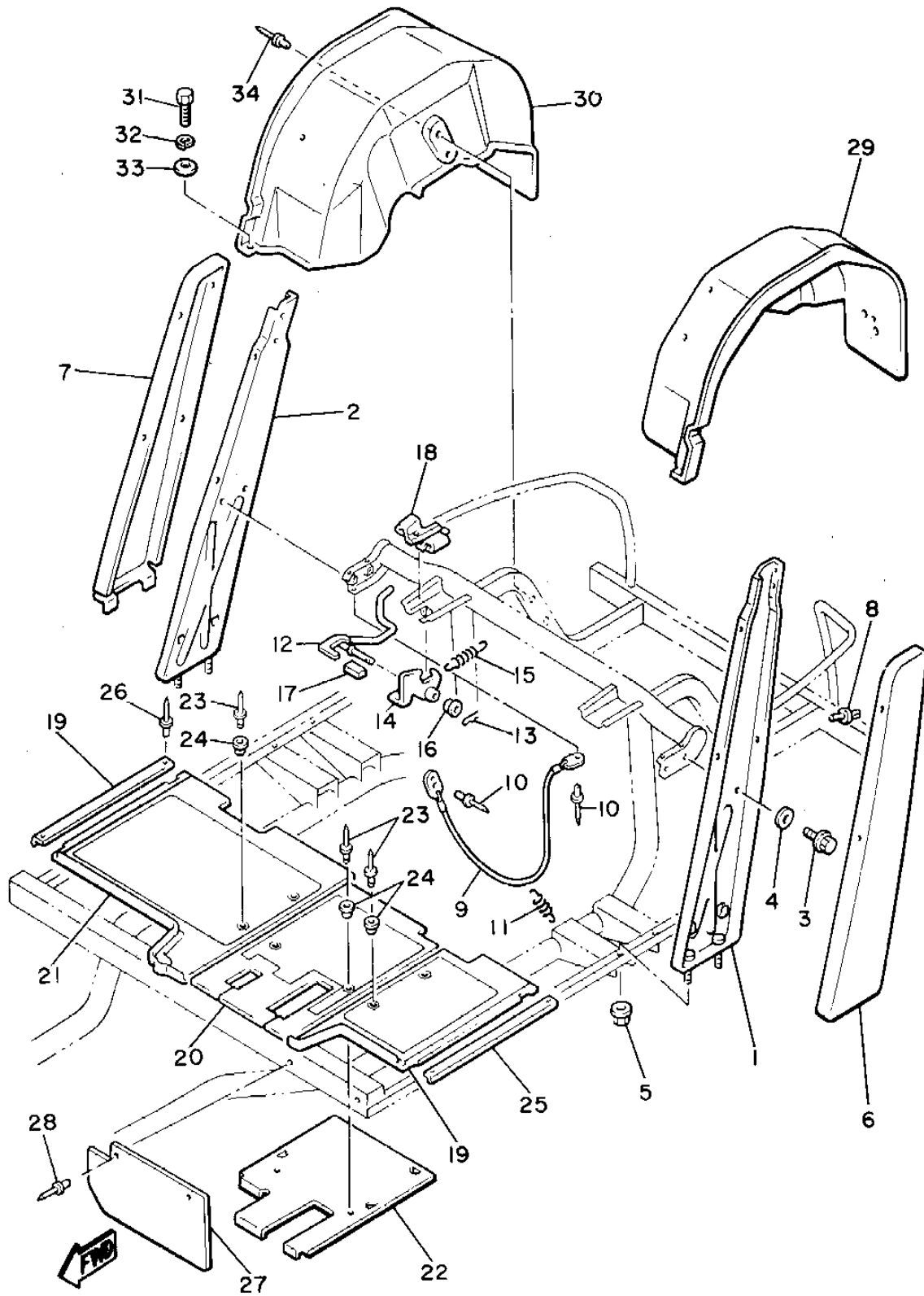

JG6100-1140

Ref. No.	Part Number	Description	Qty	Remarks
1	JG5-K813A-00-00	PILLAR, SIDE (L.H)	1	YPAD
2	JG5-K813E-00-00	PILLAR, SIDE (R.H)	1	YPAD
3	95811-08016-00	BOLT, FLANGE	4	
4	90201-08730-00	WASHER, PLATE	4	
5	95701-06500-00	NUT, FLANGE	4	
6	J55-K813F-00-00	COVER, SIDE PILLAR (L.H)	1	YPAD
7	J55-K813G-00-00	COVER, SIDE PILLAR (R.H)	1	YPAD
8	90267-63134-00	RIVET, BLIND	8	
9	J38-78229-00-00	WIRE, SEAT STOPPER	1	
10	90267-40105-00	RIVET, BLIND	2	
11	90507-08037-00	SPRING, TENSION	1	
12	JG5-K814G-00-00	LEVER, BODY LOCK	1	YPAD
13	90468-18008-00	CLIP	1	
14	J38-7814H-01-00	HOOK, BODY LOCK	1	
15	90506-18374-00	SPRING, TENSION	1	
16	J38-7814L-01-00	BUSH, LEVER END	2	
17	J38-7815H-00-00	DAMPER, LOCK	1	
18	J38-78221-00-00	SHEET, BODY MOUNTING 1	2	
19	J55-K8233-00-00	MAT, MAIN FLOOR 3	1	YPAD
20	J55-K8234-00-00	MAT, MAIN FLOOR 4	1	YPAD
21	J55-K8235-00-00	SHEET, MAIN FLOOR	1	YPAD
22	J55-K8271-00-00	SERVICE LID, PEDAL	1	YPAD
23	90267-48086-00	RIVET, BLIND	6	
24	90387-062M9-00	COLLAR	6	
25	J38-78215-00-00	PLATE, SIDE TRIM	2	
26	90267-40115-00	RIVET, BLIND	4	
27	JG5-K8187-00-00	FLAP, FRONT FENDER	2	YPAD
28	90267-48101-00	RIVET, BLIND	4	
29	JG5-K8191-00-00	PANEL, REAR FENDER 1	1	YPAD

CONTINUED ON NEXT FRAME ►



# BODY FITTING

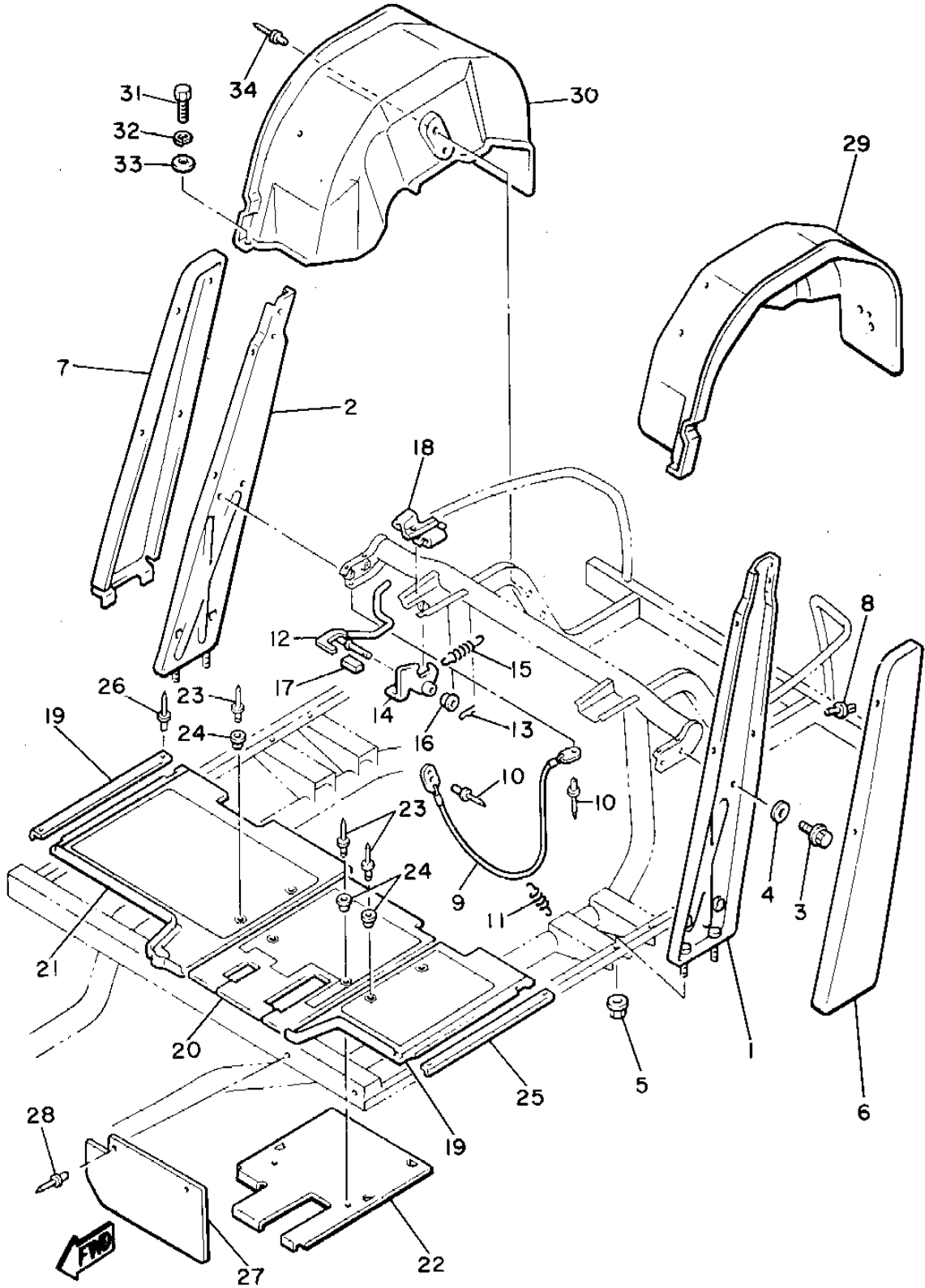

JG6100-1140

Ref. No.	Part Number	Description	Qty	Remarks
30	J55-K8192-00-00	PANEL, REAR FENDER 2	1	YPAD
31	97016-06016-00	BOLT	2	
32	92906-06100-00	WASHER, SPRING	2	
33	92906-06600-00	WASHER	2	
34	90267-48101-00	RIVET, BLIND	6	
	G9E-PARTS-BO-AR	ASSEMBLY, HARDWARE	9	OPTIONAL PART

# CARRIER

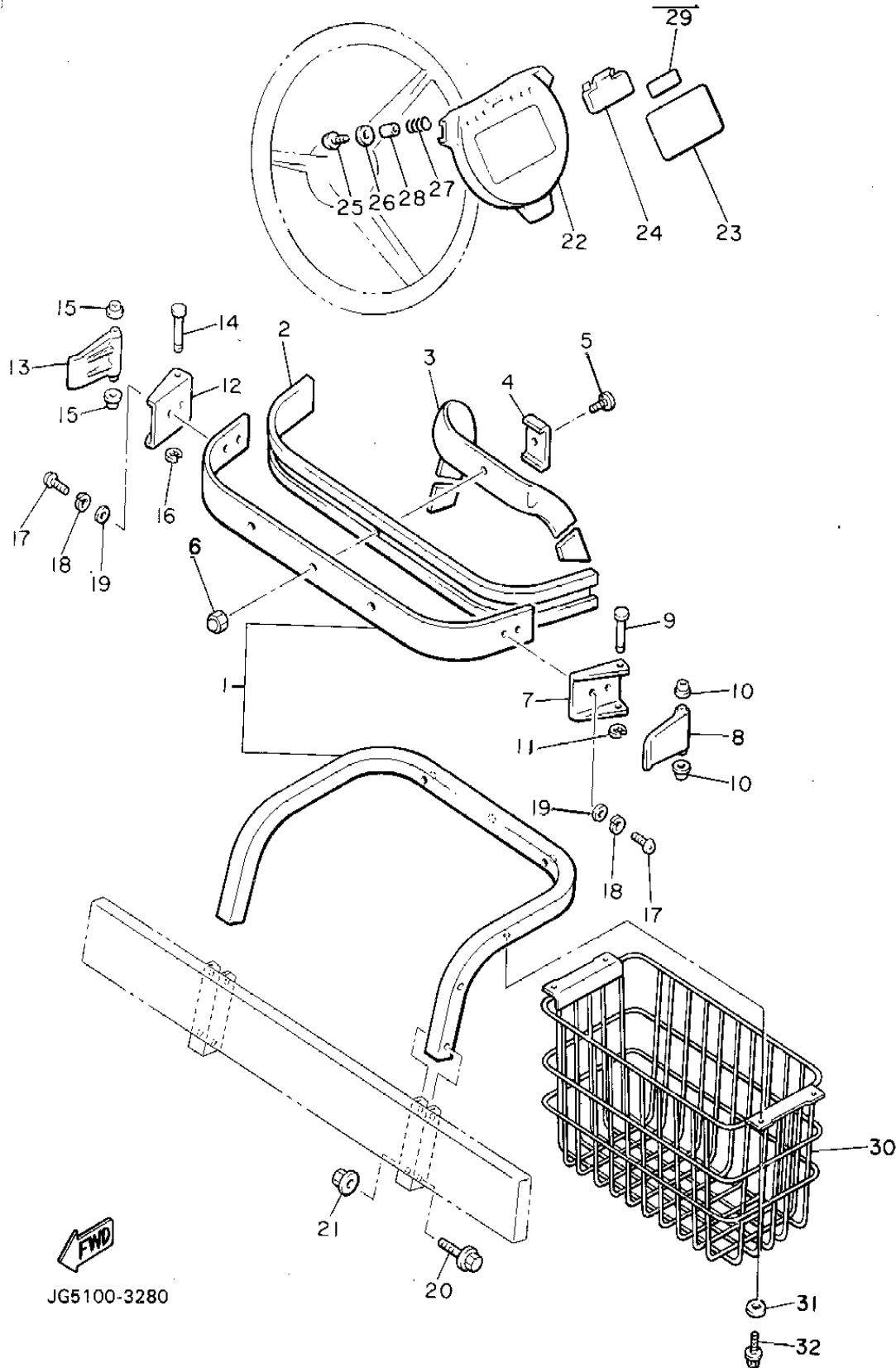

Ref. No.	Part Number	Description	Qty	Remarks
1	JG5-K8351-10-00	SUPPORT, BAG UPPER	1	YPAD
2	JF2-K8356-00-00	PAD, BAG SUPPORT	1	YPAD
3	J38-78355-00-00	BAND	1	
4	J38-78367-00-00	PLATE, ANCHOR	1	
5	98980-06016-00	SCREW, BINDING	1	
6	95380-06800-00	NUT	1	
7	J17-78157-01-00	BASE, LOCK	1	
8	J17-78368-01-00	LEVER, LOCK	1	
9	J17-78369-00-00	PIN, LEVER	1	
10	90386-06108-00	BUSH	2	
11	99080-05600-00	CIRCLIP	1	
12	J17-78157-01-00	BASE, LOCK	1	
13	J17-78368-01-00	LEVER, LOCK	1	
14	J17-78369-00-00	PIN, LEVER	1	
15	90386-06108-00	BUSH	2	
16	99080-05600-00	CIRCLIP	1	
17	98580-06010-00	SCREW, PAN HEAD (92503-06010)	4	
18	92995-06100-00	WASHER, SPRING	4	
19	92990-06200-00	WASHER	4	
20	95811-08040-00	BOLT, FLANGE	4	
21	95701-08500-00	NUT, FLANGE	4	
22	J55-K8357-00-00	HOLDER 1	1	YPAD
23	JN3-K7762-00-00	LABEL, WARNING 2	1	UR
24	J55-K8358-00-00	HOLDER 2	1	YPAD
25	97706-40525-00	SCREW, TAPPING	2	
26	90201-044H9-00	WASHER, PLAIN	2	
27	90502-10013-00	SPRING, CONICAL	2	
28	90387-046N7-00	COLLAR	2	

CONTINUED ON NEXT FRAME ►

**FWD**  
JG5100-3280

# CARRIER

Ref. No.	Part Number	Description	Qty	Remarks
29	J51-77763-00-00	LABEL, WARNING 3	1	
30	JG5-K8340-00-00	LUGGAGE RACK ASSEMBLY, REAR	1	YPAD
31	90201-08103-00	WASHER, PLAIN	4	
32	95805-08016-00	BOLT, FLANGE	4	

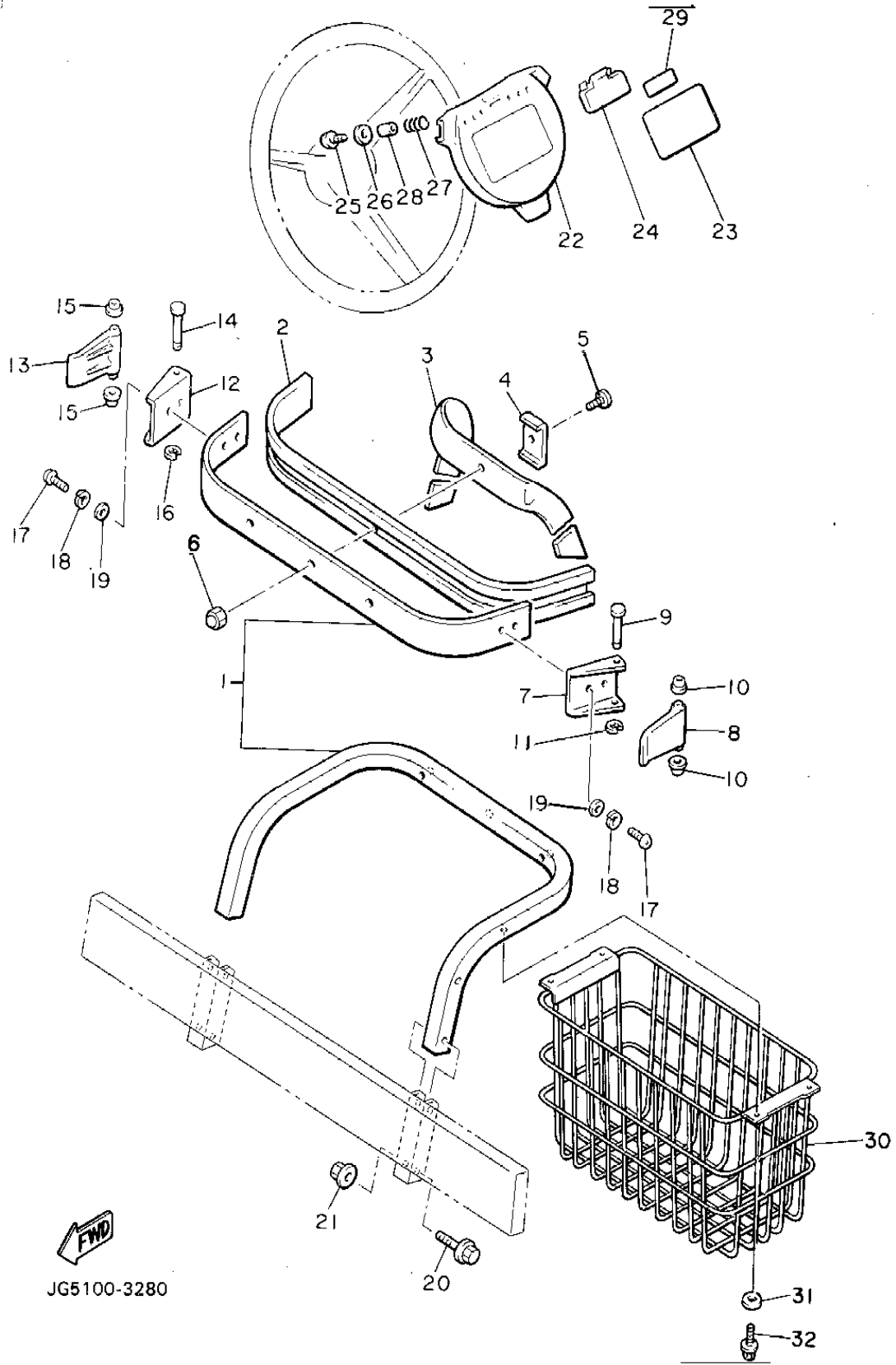

FWD  
JG5100-3280

# SEAT

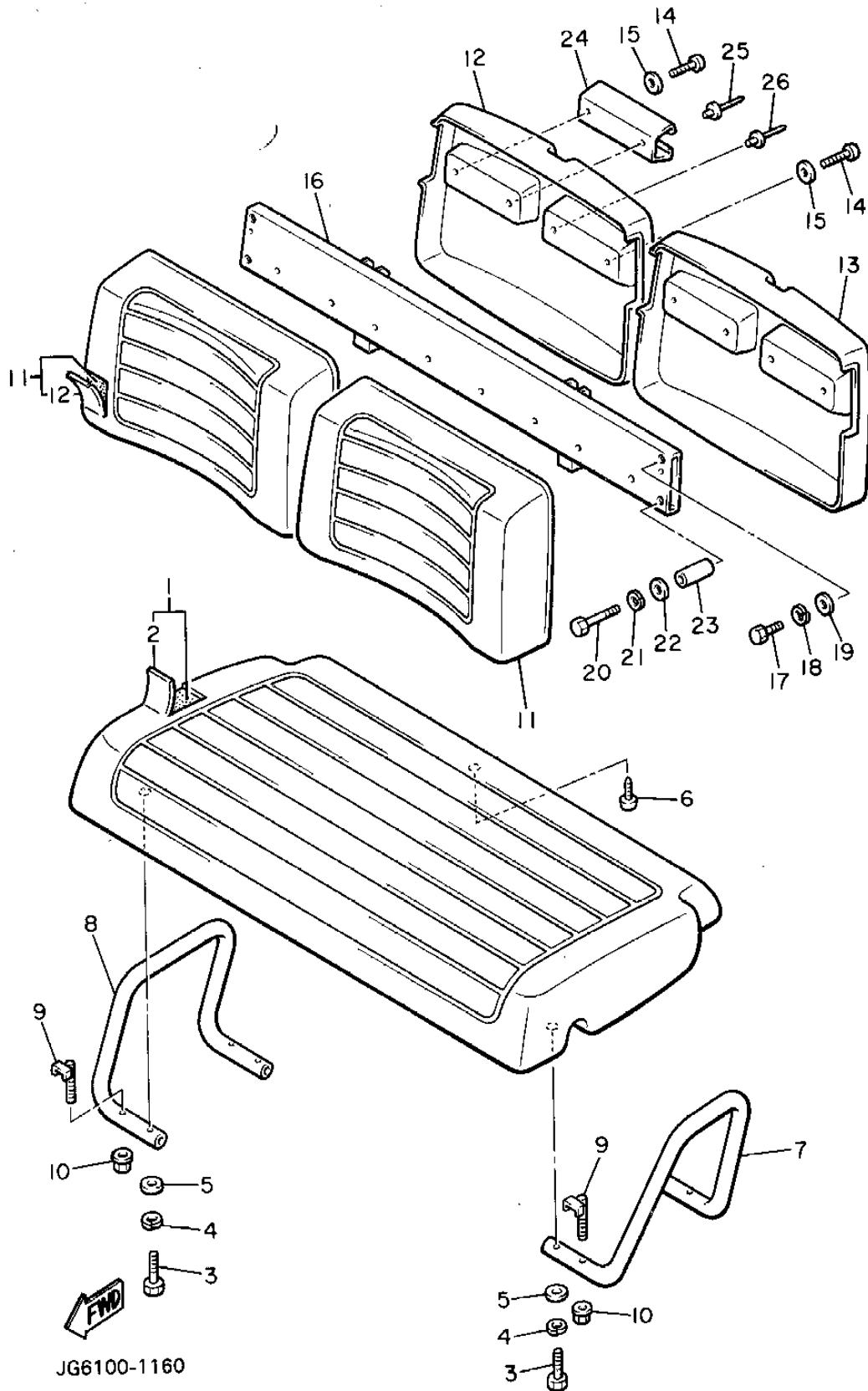

Ref. No.	Part Number	Description	Qty	Remarks
1	JG5-K8401-00-00	SEAT SUB-ASSEMBLY, CUSHION	1	YPAD
2	JG5-K8404-09-00	. COVER, SEAT	1	YPAD
3	97021-08065-00	BOLT	4	
4	92902-08100-00	WASHER, SPRING	4	
5	92990-08600-00	WASHER, PLATE	4	
6	90149-059U1-00	SCREW, PANHEAD (97701-50516)	1	
7	JG5-K8361-01-00	ARM REST 1	1	
8	JG5-78362-01-00	ARM REST 2 (J38-78362-00-00)	1	
9	J38-78384-00-00	BOLT	4	
10	95601-08200-00	NUT, U	4	
11	JG5-K8402-01-00	SEAT SUB ASSEMBLY, BACK	2	YPAD
12	JG5-K841G-09-00	. COVER, SUB-SEAT	1	YPAD
13	JG5-K8413-00-00	COVER, SEAT BACK	2	YPAD
14	98980-06045-00	SCREW, BIND	4	
15	90201-065F3-00	WASHER, PLATE	4	
16	JG5-K8423-01-00	SUPPORT, SEAT BACK	1	YPAD
17	97011-08016-00	BOLT	2	
18	92902-08100-00	WASHER, SPRING	2	
19	92990-08600-00	WASHER, PLATE	2	
20	97022-08075-00	BOLT	2	
21	92902-08100-00	WASHER, SPRING	2	
22	92990-08600-00	WASHER, PLATE	2	
23	90387-103G9-00	COLLAR	2	
24	J55-K835A-00-00	HOLDER, BALL	2	YPAD
25	90267-63047-00	RIVET, BLIND	2	
26	90267-63134-00	RIVET, BLIND	2	
	G9E-PARTS-BO-AR	ASSEMBLY, HARDWARE	9	OPTIONAL PART

# STARTING MOTOR

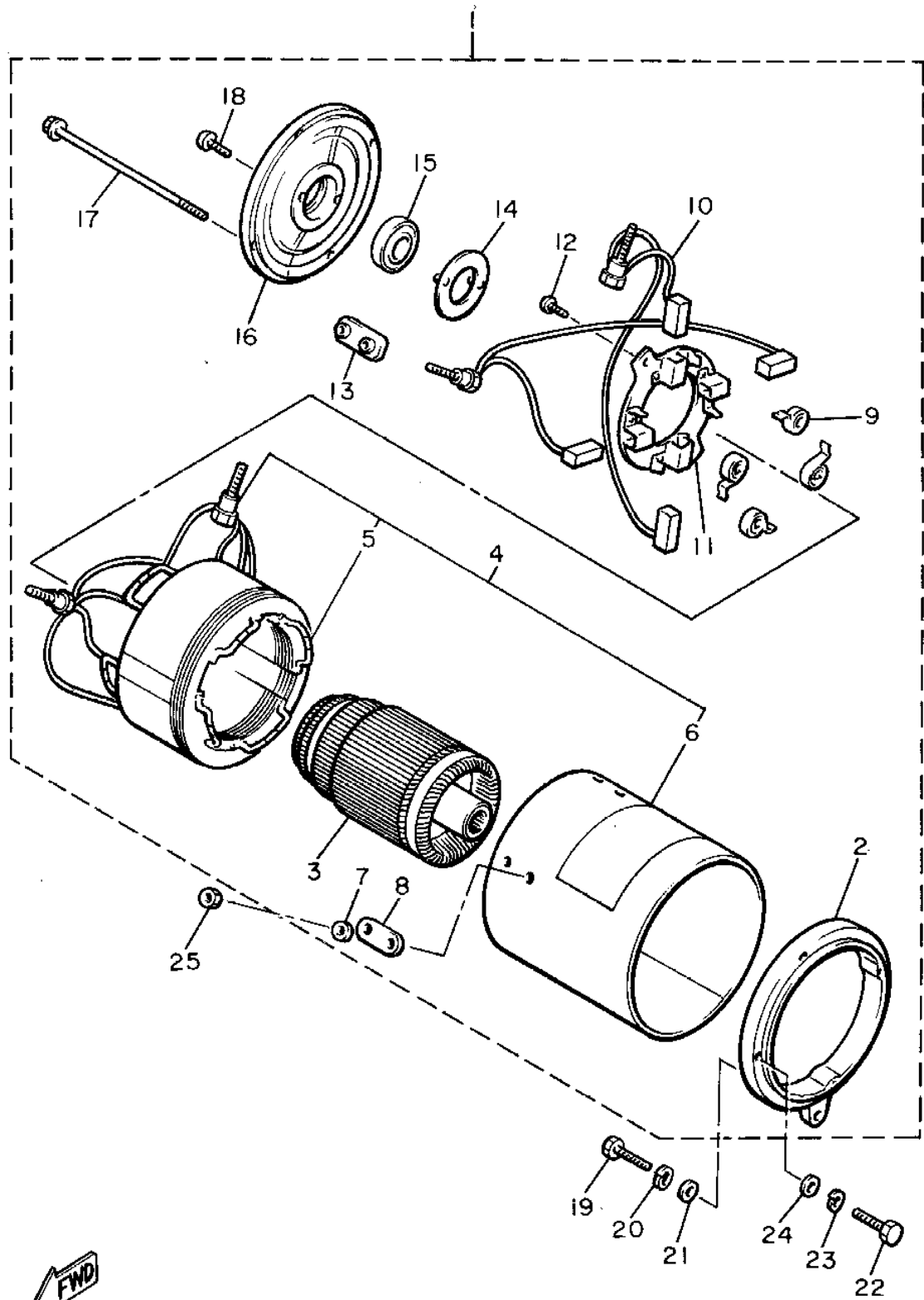

Ref. No.	Part Number	Description	Qty	Remarks
1	JG6-H1890-01-00	MOTOR ASSEMBLY (JG6-H1890-00-00)	1	SEE NOTE
2	JG6-H183J-00-00	. BRACKET, FRONT	1	SEE NOTE
3	JG6-H1850-00-00	. ARMATURE, ASSEMBLY	1	SEE NOTE
4	JG6-H1810-10-00	. STATOR ASSEMBLY	1	SEE NOTE
5	JG6-H1160-10-00	. . FIELD COIL	1	SEE NOTE
6	JG6-H181-70-00	. . STATOR	1	SEE NOTE
7	JG6-H1894-00-00	. WASHER	4	SEE NOTE
8	JG6-H1843-00-00	. WASHER 1	2	SEE NOTE
9	J56-H1813-00-00	. SPRING, BRUSH 1	4	SEE NOTE
10	JG6-H1801-00-00	. BRUSH ASSEMBLY	2	SEE NOTE
11	JG6-H1840-00-00	. BRUSH HOLDER	1	SEE NOTE
12	JG6-H1848-00-00	. SCREW, BRUSH HOLDER	2	SEE NOTE
13	JG6-H1824-00-00	. WASHER 2	2	SEE NOTE
14	JG6-H1856-00-00	. RETAINER	1	SEE NOTE
15	J56-H1857-00-00	. RETAINER	1	SEE NOTE
16	JG6-H1822-00-00	. BRACKET, ELECTRIC	1	SEE NOTE
17	JG6-H1828-00-00	. BOLT 2	4	SEE NOTE
18	JG6-H1846-00-00	. SCREW 1	2	SEE NOTE
19	97017-08025-00	BOLT	1	SEE NOTE
20	92902-08100-00	WASHER, SPRING	1	SEE NOTE
21	92990-08600-00	WASHER, PLATE	1	SEE NOTE
22	97395-06055-00	BOLT (97313-06055-00)	3	SEE NOTE
23	92995-06100-00	WASHER, SPRING	3	SEE NOTE
24	90201-06643-00	WASHER, PLATE	3	SEE NOTE
25	JG6-H1872-00-00	NUT, SPECIAL	4	SEE NOTE



JH7100-1170

# ELECTRIC MOTOR

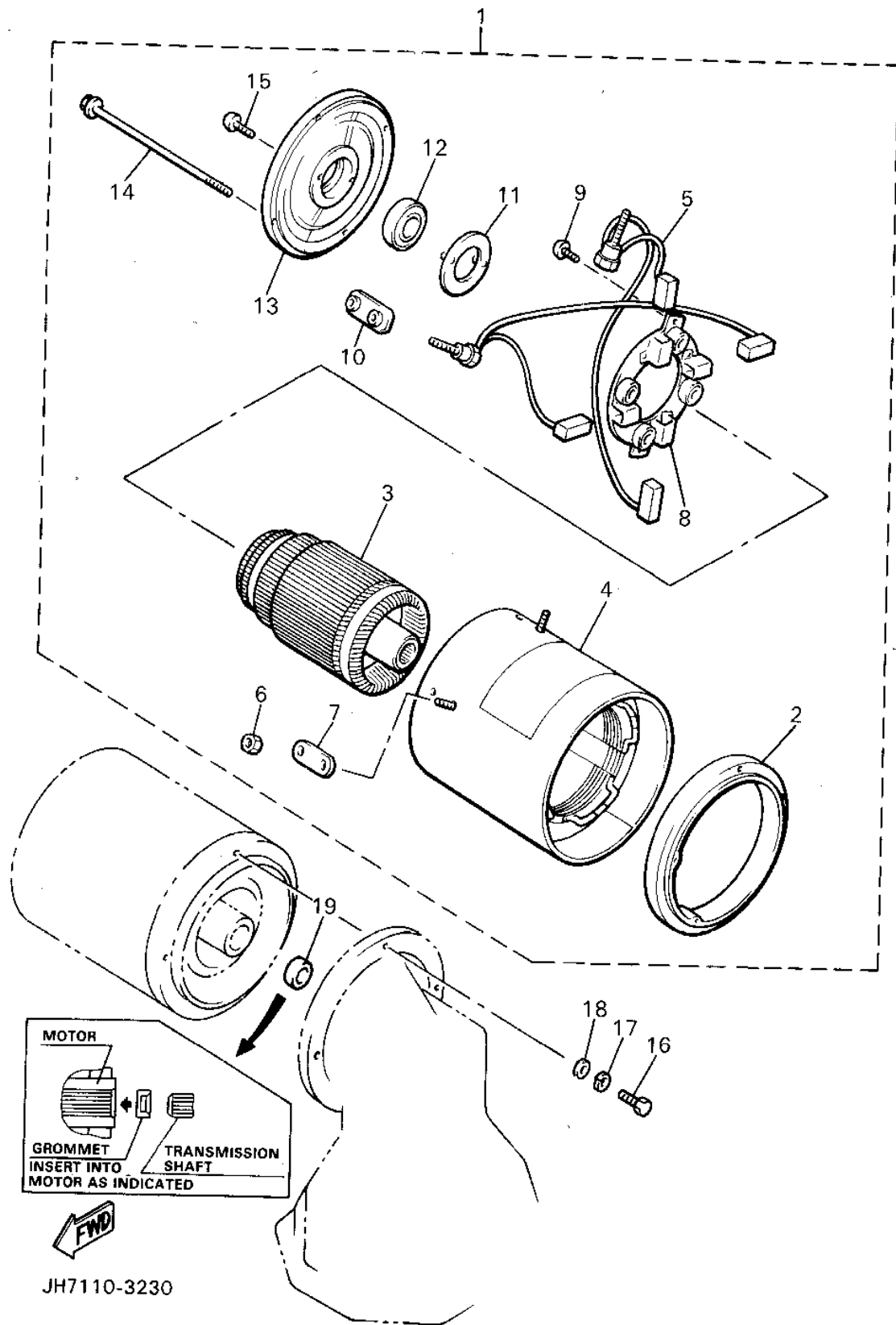

Ref. No.	Part Number	Description	Qty	Remarks
1	JH7-H1890-00-00	MOTOR ASSEMBLY	1	SEE NOTE
2	JH7-H183J-00-00	. BRACKET, FRONT	1	SEE NOTE
3	JH7-H1850-00-00	. ARMATURE ASSEMBLY	1	SEE NOTE
4	JH7-H1810-00-00	. STATOR ASSEMBLY	1	SEE NOTE
5	JH7-H1801-00-00	. BRUSH SET	1	SEE NOTE
6	JH7-H1872-00-00	. NUT, SPECIAL	4	SEE NOTE
7	J51-H1843-00-00	. WASHER 1	2	SEE NOTE
8	JH7-H1840-00-00	. BRUSH HOLDER ASSEMBLY	1	SEE NOTE
9	JH7-H1848-00-00	. SCREW, BRUSH HOLDER	2	SEE NOTE
10	JG6-H1824-00-00	. WASHER 2	2	SEE NOTE
11	JH7-H1856-00-00	. BEARING	1	SEE NOTE
12	J56-H1857-00-00	. RETAINER	1	SEE NOTE
13	JH7-H1822-00-00	. BRACKET, STARTING MOTOR	1	SEE NOTE
14	JG6-H1828-00-00	. BOLT 2	4	SEE NOTE
15	JH7-H1846-00-00	. SCREW	2	SEE NOTE
16	90101-06857-00	BOLT	3	SEE NOTE
17	90215-06811-00	WASHER, LOCK	3	SEE NOTE
18	90201-068E2-00	WASHER, PLATE	3	SEE NOTE
19	JH7-H1829-00-00	GROMMET	1	SEE NOTE

JH7110-3230

# CONTROLLER 1

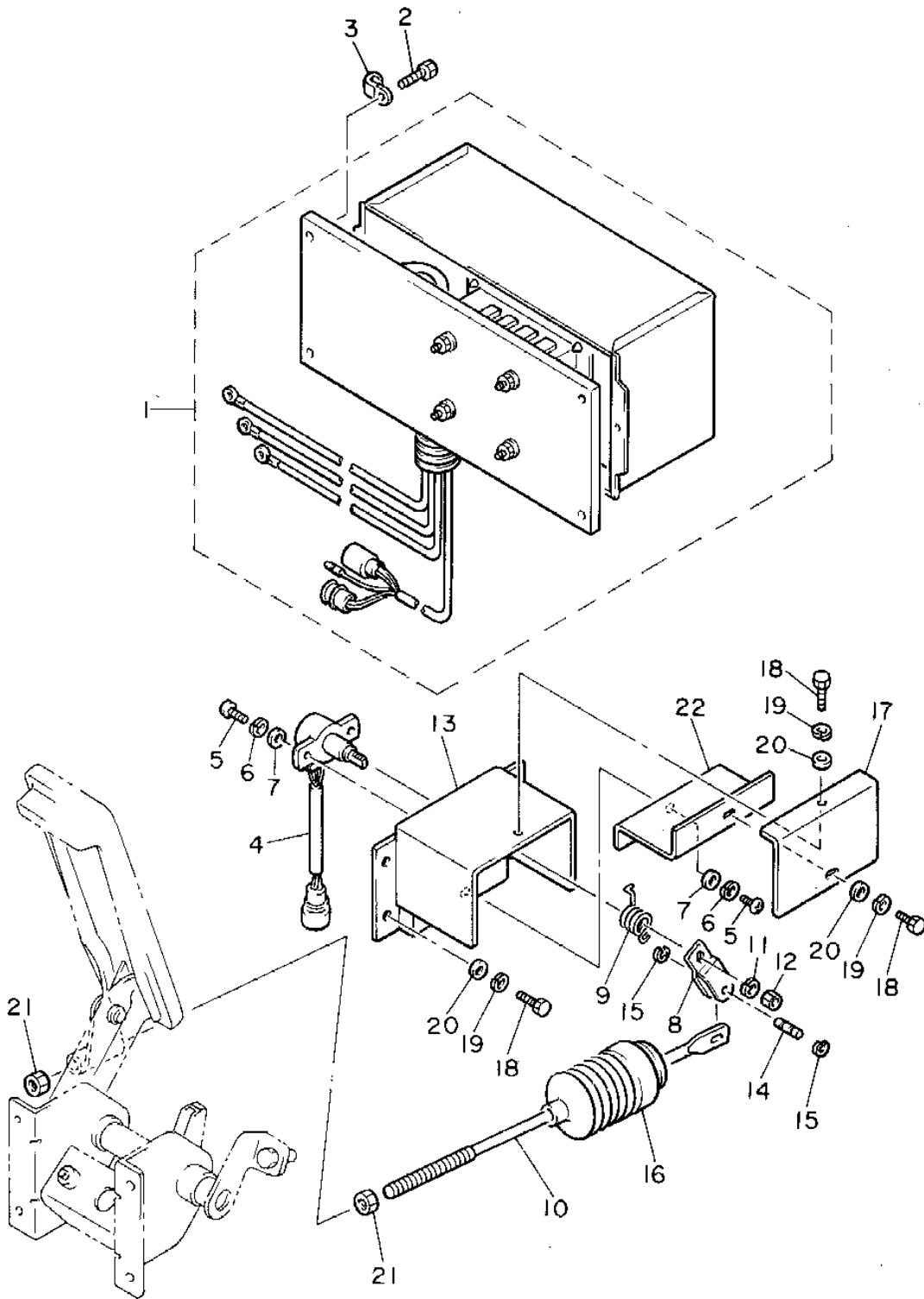

Ref. No.	Part Number	Description	Qty	Remarks
1	JF3-86510-11-00	MOTER CONTROL UNIT ASSEMBLY	1	
2	90105-06707-00	BOLT (95023-06016-00)	4	
3	90465-06038-00	CLAMP	1	
4	JF3-85885-02-00	THROTTLE SENSOR ASSEMBLY	1	
5	98580-05016-00	SCREW, PAN HEAD	3	
6	92990-05100-00	WASHER, SPRING	3	
7	92901-05600-00	WASHER, PLATE	3	
8	JF3-2625H-00-00	ARM, THROTTLE	1	
9	JF3-27825-00-00	SPRING, RETURN	1	
10	JF3-27241-00-00	ROD, JOINT	1	
11	92995-06100-00	WASHER, SPRING	1	
12	95601-06200-00	NUT, U FLANGE	1	
13	JF3-27981-00-00	BRACKET, THROTTLE	1	
14	JF3-27813-00-00	PIN, PEDAL CRANK	1	
15	99080-04600-00	CIRCLIP (E)	2	
16	JF3-27486-00-00	COVER 1	1	
17	JF3-27487-00-00	COVER 2	1	
18	97001-05016-00	BOLT (97002-05016-00)	6	
19	92990-05100-00	WASHER, SPRING	6	
20	92901-05600-00	WASHER, PLATE	6	
21	95303-08700-00	NUT	2	
22	JF3-27445-00-00	PLATE 1	1	

JH7100-3180

# CONTROLLER 2

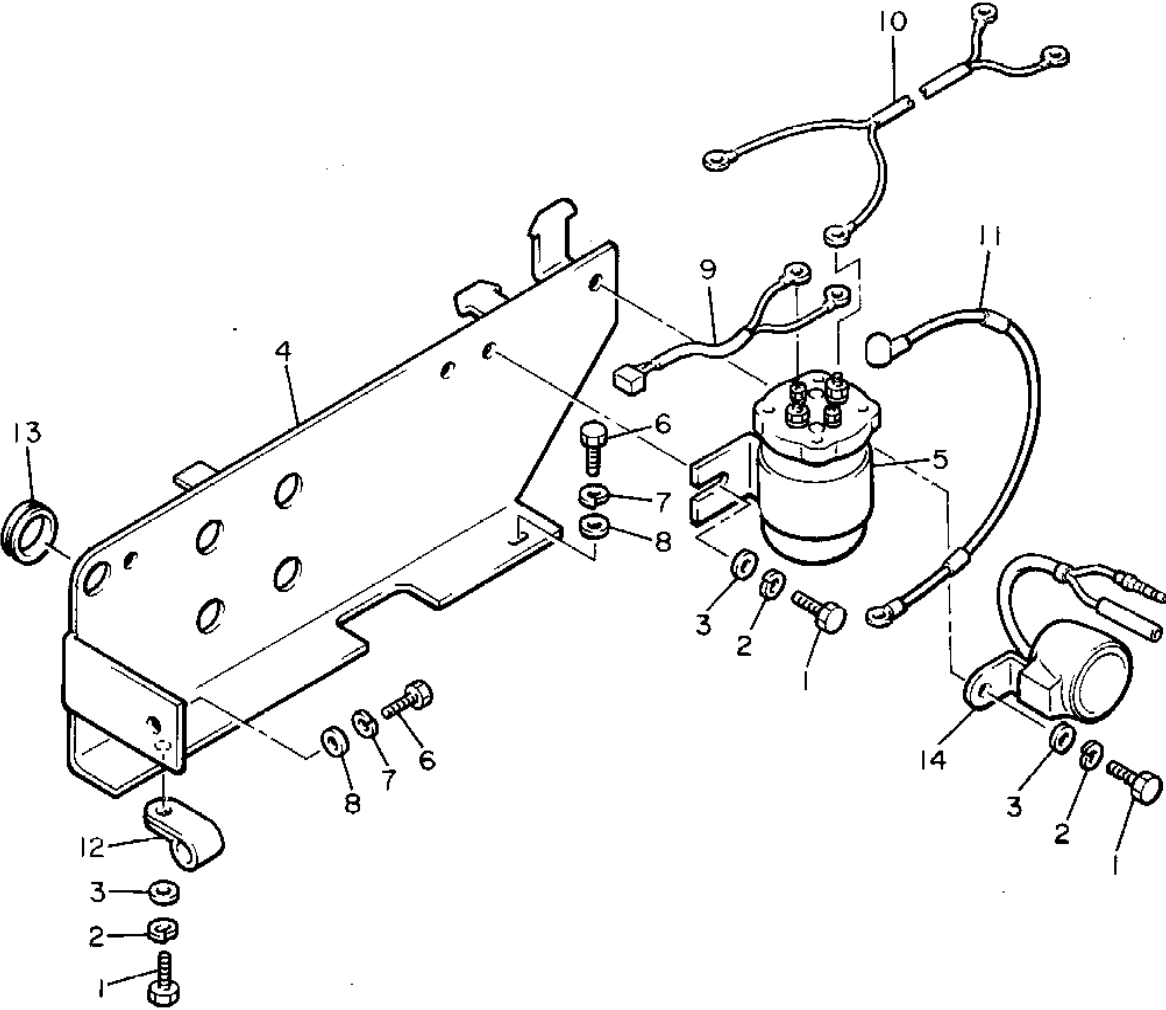

Ref. No.	Part Number	Description	Qty	Remarks
1	97011-06016-00	BOLT	1	
2	92995-06100-00	WASHER, SPRING	3	
3	92990-06600-00	WASHER, PLATE	3	
4	JH7-H6141-01-00	PLATE, CONTROLLER	1	YPAD
5	JF3-H1950-00-00	RELAY ASSEMBLY	1	YPAD
6	97011-08016-00	BOLT	2	
7	92902-08100-00	WASHER, SPRING	2	
8	92990-08600-00	WASHER, PLATE	2	
9	JF2-82105-00-00	WIRE HARNESS	1	
10	J41-82542-00-00	WIRE, LEAD	1	
11	JH7-H2115-00-00	WIRE, PLUS LEAD	1	YPAD
12	90465-08M08-00	CLAMP	2	
13	90480-21425-00	GROMMET	1	
14	JF3-83383-02-00	BUZZER	1	



JH7100-3190



# ELECTRICAL 1

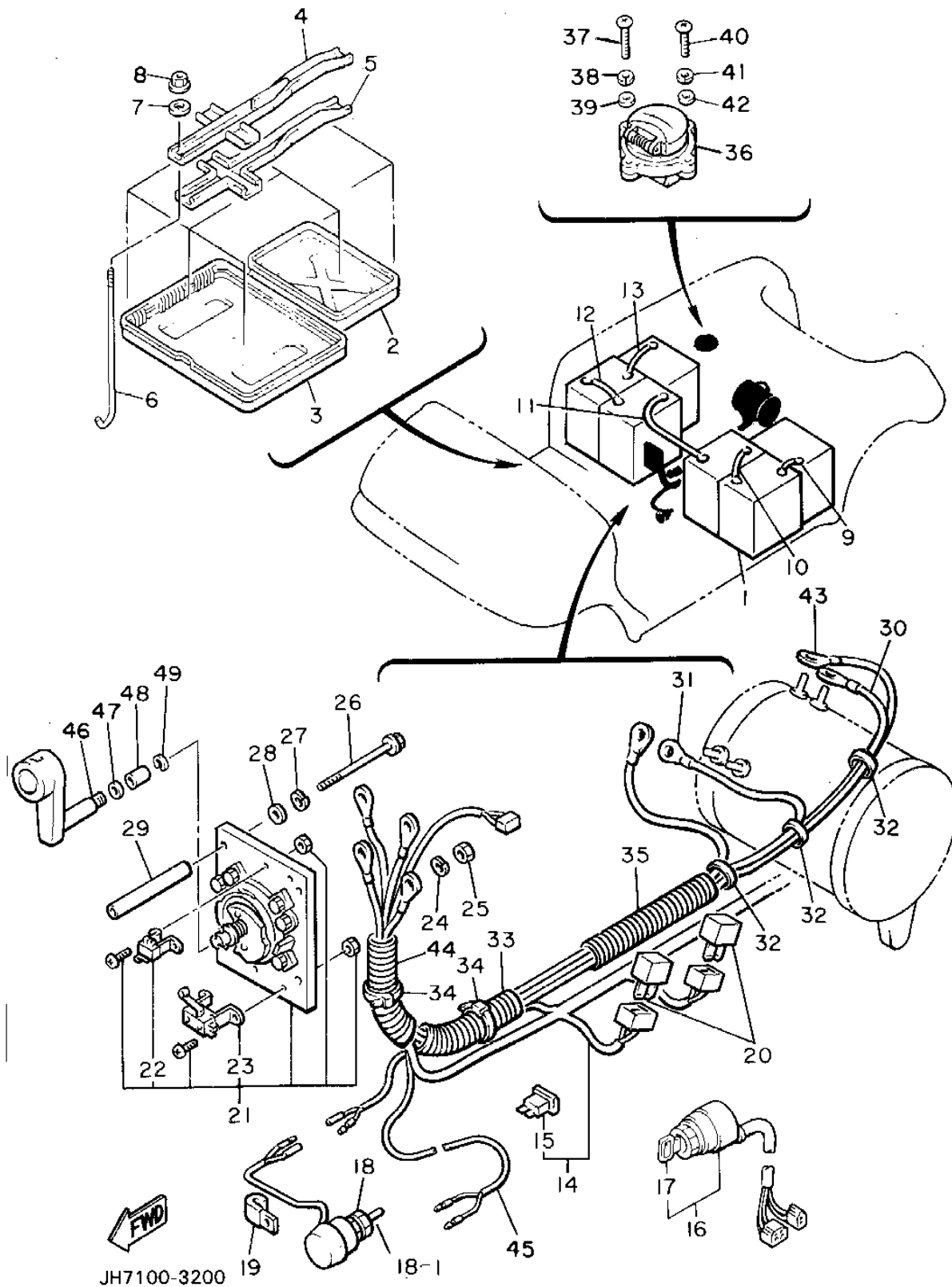

Ref. No.	Part Number	Description	Qty	Remarks
1	UNA-VAILA-BL-EI	0 0 .....		
2	J56-H2122-00-00	SEAT, BATTERY .....	2	YPAD
3	J56-H2123-00-00	SEAT, BATTERY .....	2	YPAD
4	J41-82136-01-00	PLATE, BATTERY FITTING ...	2	
5	J41-82121-00-00	PAD, BATTERY .....	2	
6	J14-82133-01-00	SCREW, FITTING .....	4	
7	90201-06765-00	WASHER, PLATE .....	4	
8	95701-06500-00	NUT, FLANGE .....	4	
9	J56-H2127-00-00	WIRE, LEAD 2 .....	1	YPAD
10	J56-H2117-00-00	WIRE, LEAD .....	1	YPAD
11	J56-H2149-00-00	WIRE, LEAD 3 .....	1	YPAD
12	J56-H2127-00-00	WIRE, LEAD 2 .....	1	YPAD
13	J56-H2117-00-00	WIRE, LEAD .....	1	YPAD
14	JH7-82590-01-00	WIRE HARNESS ASSEMBLY ..	1	
15	42X-82151-00-00	. FUSE (10A-BL) .....	2	
16	J55-82510-00-00	MAIN SWITCH ASSEMBLY ...	1	
17	J17-82511-20-00	. KEY, MAIN SWITCH .....	1	
18	J41-82550-02-00	STOP SWITCH ASSEMBLY ...	1	
19	90465-06038-00	CLAMP .....	1	
20	J44-81980-60-00	DIODE .....	2	
21	JF3-82917-01-00	SWITCH .....	1	
22	J41-82617-00-00	. SWITCH .....	1	
23	J41-82817-00-00	. MICRO SWITCH .....	1	
24	92995-06100-00	WASHER, SPRING .....	4	
25	95601-06200-00	NUT, U FLANGE .....	4	
26	97021-06080-00	BOLT (97001-06080-00) .....	4	
27	92995-06100-00	WASHER, SPRING .....	4	
28	92990-06600-00	WASHER, PLATE .....	4	
29	90387-061M8-00	COLLAR .....	4	

CONTINUED ON NEXT FRAME ►

# ELECTRICAL 1

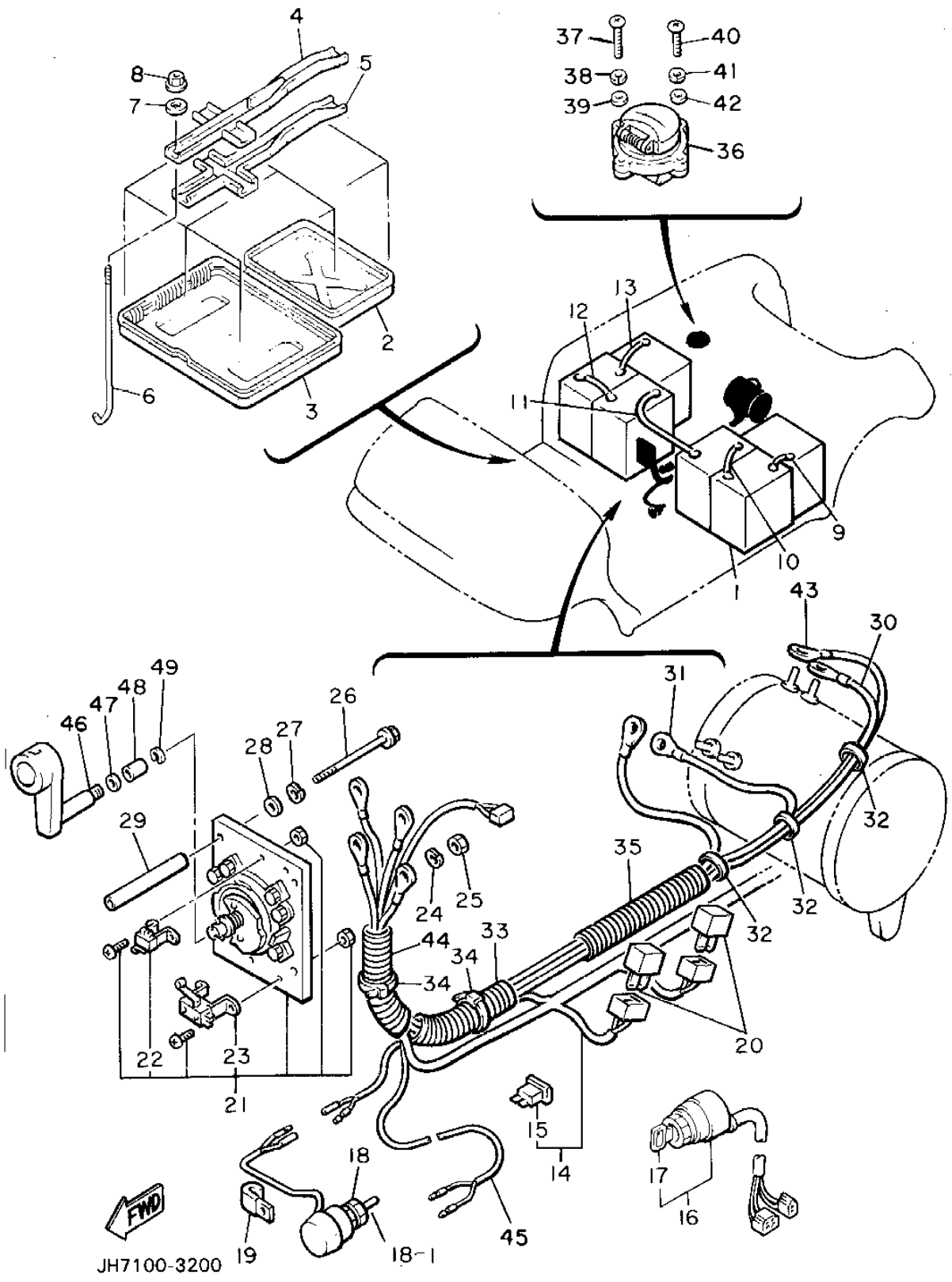

Ref. No.	Part Number	Description	Qty	Remarks
30	JH7-H2521-00-00	WIRE, LEAD .....	1	YPAD
31	JH7-H2531-00-00	WIRE, LEAD .....	1	YPAD
32	90601-200U1-00	BAND .....	3	
33	J56-H7197-00-00	TUBE 2 .....	1	YPAD
34	12R-82591-00-00	BAND .....	2	
35	J56-H7196-00-00	TUBE 1 .....	1	YPAD
36	JF3-86181-00-00	RECEPTACLE .....	1	
37	98506-05035-00	SCREW, PAN HEAD .....	2	
38	92906-05100-00	WASHER, SPRING .....	2	
39	92906-05600-00	WASHER, PLATE .....	2	
40	98586-05016-00	SCREW, PAN HEAD .....	2	
41	92906-05100-00	WASHER, SPRING .....	2	
42	92906-05600-00	WASHER, PLATE .....	2	
43	JH7-H6171-00-00	WIRE, LEAD 1 .....	1	YPAD
44	JH7-H7197-00-00	TUBE 2 .....	1	YPAD
45	JH7-H6527-00-00	WIRE 7 .....	1	YPAD
46	J41-46381-00-00	KNOB, SHIFT .....	1	
47	90201-12474-00	WASHER, PLATE .....	1	
48	J41-46394-00-00	JOINT .....	1	
49	99001-08600-00	CIRCLIP .....	1	
	G9E-PARTS-BO-AR	ASSEMBLY, HARDWARE .....	9	OPTIONAL PART
18-1	JF2-82532-00-00	. CAP, RUBBER .....	1	

## G9A/E BRAKE PART CHANGES

### INTRODUCTION

Beginning with the 1992 model, the brake assembly parts on the G9 are changed. The brake system parts on the 1992 and later models are

not interchangeable with those on the 1991 models. See Parts Information below for details.

### AFFECTED UNITS

#### Old Style Brakes (2 springs):

G9AG All  
G9EG All

#### New Style Bendix Brakes (3 springs):

G9AH JG5-100101 ~  
G9EH1 G6-100101 ~  
G9EH2 JH7-000125 ~  
1993 G9A,E, All

### PARTS INFORMATION

#### Identification Procedures

The 1992 model brake systems are manufactured by Bendix and have a part number sticker on the backing plate that indicates either Left Side or Right Side. The 1991 models do **not** have this sticker. Also, the new Bendix system contains 3 springs inside the drum whereas the 1991 system has 2 springs. Refer to the illustration.

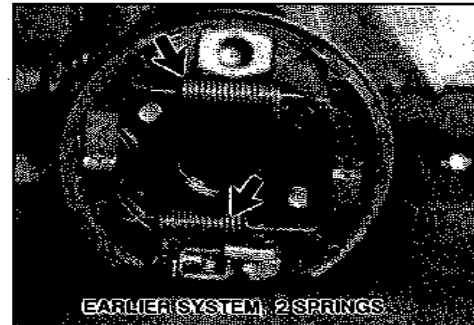

#### 1992 Model New Style Bendix Brakes

Ref. No.	Part Number	Description	Remarks
1.	JG5-F7290-00-00	Backing Plate Ass'y (LH)	
	JG5-F7280-00-00	Backing Plate Ass'y (RH)	
2.	JG5-F5330-00-00	Brake Shoe Set	(1 Wheel Set)
3.	JG5-F819G-00-00	Spring Set	(1 Wheel Set)
4.	JG5-F7286-00-00	Dust Cover	

**NOTE:** Be sure you order and use the correct parts for whichever year car you are repairing.

Refer to the proper parts microfiche for additional parts information.

PAGE 1 OF 2

### WARRANTY INFORMATION

This bulletin is for information only. No warranty applies.

PAGE 2 OF 2

ROUTE TO:

SERVICE

PARTS

WARRANTY

SALES

## G9EJ TRANSMISSION CHANGES

### INTRODUCTION

A new Transmission/Rear Axle Assembly will be used on the 1993 G9EJ Fleet Master electric car, beginning with November production. Parts used in the new system

are not interchangeable with previous G9E models. See Parts Information for details.

### AFFECTED UNITS

G9EJ JH7-100311 ~ 100410  
JH7-101111 ~ and later

Note: This bulletin does not apply to GAS cars.

### IDENTIFICATION PROCEDURES

The new style rear axle assembly is manufactured by Dana. The parts are not interchangeable with the earlier rear axle assembly.

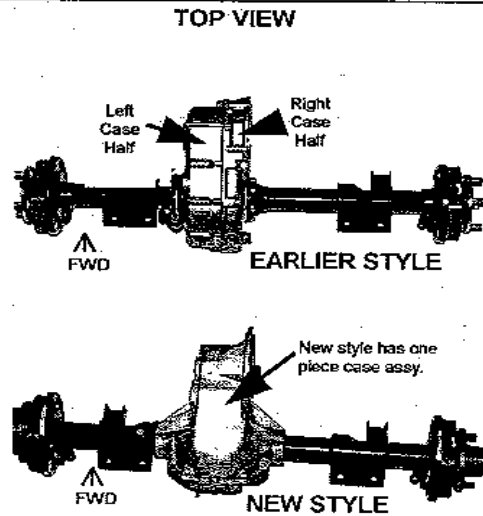

### SERVICE INFORMATION

1. At six months, check the oil level.

Remove fill/level plug. Check that oil is flowing from the level plug hole.

If not, add oil until it begins to flow out.

Oil fill/level plug tightening torque:  
32 ft. lb. (4.4 m.kg)

2. After two years service, change the oil in the transmission/axle assembly.

To drain, remove the ten cover plate hex bolts. Place a drain pan under the transmission. Using a gasket scraper, separate the cover plate from the housing.

To re-install, clean the surfaces, then apply a small bead of Quick Gasket sealant to the case surface and into the 10 bolt holes.

Torque the 10 hex bolts in a criss-cross pattern to 18~28 ft.lbs.(2.48 ~ 3.87 m.kg.)

Remove the oil fill/level plug and fill case with gear oil. Reinstall plug and tighten to 32 ft.lb. (4.4m.kg)

Recommended oil:

P/N : ACC-11001-35-00  
SAE 90 GEAR OIL

Oil quantity:

0.32 qt. (0.3 liter, 0.25 Imp qt.)

### CHECKING OIL LEVEL

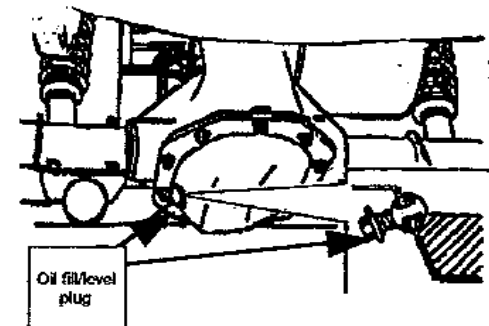

### CHANGING OIL



**CAUTION**  
Be careful not to damage the housing sealing surface or deform the cover plate.

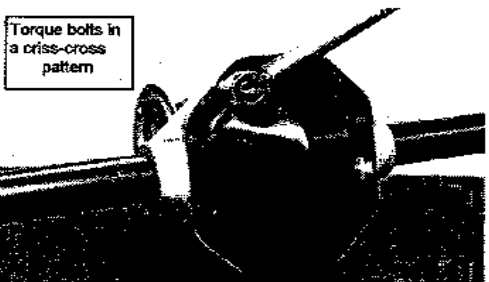

### WARRANTY INFORMATION

This bulletin is for information purposes only. No warranty applies.

SEE NEXT PAGE FOR PARTS INFORMATION

**PARTS INFORMATION**

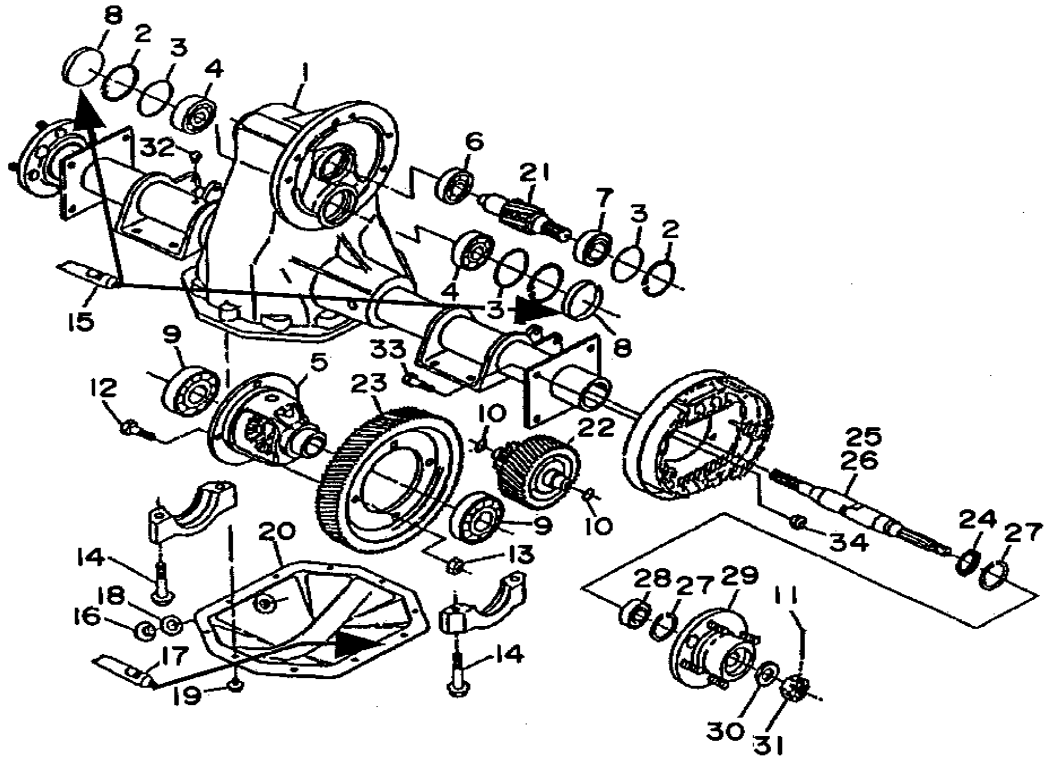

Item	Part Number	Qty	Description
1	JH7-G6310-00-00	1	Case Assy
2	93420-50804-00	3	Circlip
3	93210-47888-00	3	O-ring
4	93306-303Y6-00	2	Bearing
5	JH7-G6410-00-00	1	Diff. Assy
6	93306-203X1-00	1	Bearing
7	93306-005Y1-00	1	Bearing
8	JH7-G3396-00-00	2	Plug, Blind
9	93306-D07Y0-00	2	Bearing
10	93210-14889-00	2	O-ring
11	91490-25025-00	2	Pin, Split
12	90101-10854-00	4	Bolt, Hex
13	90170-10840-00	4	Nut, Lock
14	90105-10840-00	4	Bolt, Flange
15	ACC-11001-31-00	1	Yamabond 5
16	JH7-G5341-00-00	1	Plug, Fill
17	ACC-11001-05-01	1	Quick Gasket (RTV)

Item	Part Number	Qty	Description
18	90201-158E0-00	1	Washer
18	90101-08856-00	10	Bolt, Hex
20	JH7-G6312-00-00	1	Plate, cover
21	JH7-G6321-00-00	1	Shaft, Input
22	JH7-G6350-00-00	1	Counter Gear Assy
23	JH7-G6421-00-00	1	Gear, Ring
24	93101-24822-00	2	Seal, Oil
25	JH7-G8512-00-00	1	Shaft, RR Axle 2
26	JH7-G6511-00-00	1	Shaft, RR Axle 1
27	93420-44805-00	4	Circlip
28	93306-004X5-00	2	Bearing
29	JH7-G6514-00-00	2	Hub, RR Axle
30	90201-198E1-00	2	Washer
31	90171-16813-00	2	Nut, Hex
32	JH7-G5619-00-00	1	Cap
33	90101-08855-00	8	Bolt, Hex
34	90170-08841-00	8	Nut, Hex

ROUTE TO:  SERVICE  PARTS  WARRANTY  SALES PAGE 3 OF 3